

FORZA

DOORS & FRAMES



FORZA FIRE CERTIFICATE

PLACE IN BUILDING FIRE SAFETY MANUAL

(BS9999:2017 - Section 9, Annex H)

KEEP! SIGN! FILE!

FIRE RESISTANT TIMBER FD60 FIRE DOORS & FRAMES

TO BS 476: PART 22 : 1987
CERTIFICATE NO. FRTD497

This product certificate certifies that FORZA DOORS LTD Manufacture in the UK the following fire doors and door assemblies: **Forza Flush & Vision Panelled FD60 & FD60s** and have satisfied the requirements of The IFC CERTIFICATION LTD scheme that includes the testing of products to BS476: Part 22, the inspection of Factory Production Control and continuing surveillance audits and testing of samples taken from production.

The product specifications are detailed in the FD60 Field of Application report reference PAR/10896/rev I. The report concludes that the door assemblies within the scope of approval may be installed in either orientation and so be exposed to fire conditions from either face.



IFC Certification Ltd Tel: +44 (0)1844 275500 www.ifccertification.com	FD TYPE:	IFC Certification Ltd Tel: +44 (0)1844 275500 www.ifccertification.com	FD TYPE:	FORZA FIRE DOOR NO:
FD 60	(PLEASE TICK)	FD 60s	(PLEASE TICK)	
BS 476:PART 22		BS 476:PART 22		



✓ CONTRACTORS INSTALLATION STATEMENT & CRITICAL CHECKLIST

PROJECT DOOR REF:	ELEVATION TYPE:
FLOOR:	
BUILDING:	FLUSH <input type="checkbox"/> OR VISION PANEL <input type="checkbox"/>
LOCATION:	INTUMESCENT: LEAF <input type="checkbox"/> FRAME <input type="checkbox"/>
FRAME MATERIAL: TIMBER <input type="checkbox"/> ALUMINIUM <input type="checkbox"/> STEEL <input type="checkbox"/>	
SUPPORTING CONSTRUCTION:	<input type="checkbox"/> PROPRIETARY DEMOUNTABLE AND RELOCATABLE PARTITION SYSTEM Limitation of allowable elevations/leaf sizes and permitted ironmongery as tested and specified by the proprietary demountable and relocatable partition manufacturer have been adhered to and take total precedence over Forza data.
<input type="checkbox"/> TIMBER STUD PLASTERBOARD PARTITION <input type="checkbox"/> STEEL STUD PLASTERBOARD PARTITION <input type="checkbox"/> FORZA FIRE SCREEN <input type="checkbox"/> MASONRY WALL	
PROJECT SPECIFIC ENGINEERING ASSESSMENT REF:	

This Fire Door has been installed in accordance with the Forza installation guidance and specification by the trained installation team of:

COMPANY:

SIGNED:

(On behalf of the Contractor)

DATE:

TICK HERE ON COMPLETION

✓ CORRECT INSTALLATION - MUST BE OBSERVED

1. Frame to wall gaps /packing /gap sealant
2. Hinges/Pivots position & no missing screws
3. Door to Frame & Threshold gaps
4. Fire seals (intumescent) in position
5. Smoke seals allow door to shut and fill all gaps
6. Lockset engages/releases
7. Closer suitably adjusted to close door
8. "Fire Door Keep Shut" sign visible on door or frame

FIRE DOOR LABEL AFFIX TO DOOR INTUMESCENT STRIP OR FRAME ON INSTALL

Follow us on: @forzadoorsltd forzadoorsltd
Find us on: forzadoorsltd App Stores

FIRE DOOR LABEL AFFIX TO DOOR INTUMESCENT STRIP OR FRAME ON INSTALL



Za' says:
"Always follow my installation instructions and repair techniques!"
Lets get it right!

Forza Installation Guidance

For further information and guidance, detailed construction and installation drawings and video guides log-on to our website by scanning the QR code opposite or visit:

www.forza-doors.com

Alternatively call 01403 711126 to speak to one of our technical advisors.



FD60 - TIMBER DOOR & FRAME SPECIFICATION & INSTALLATION GUIDE

DOOR ASSEMBLY ELEVATION TYPES

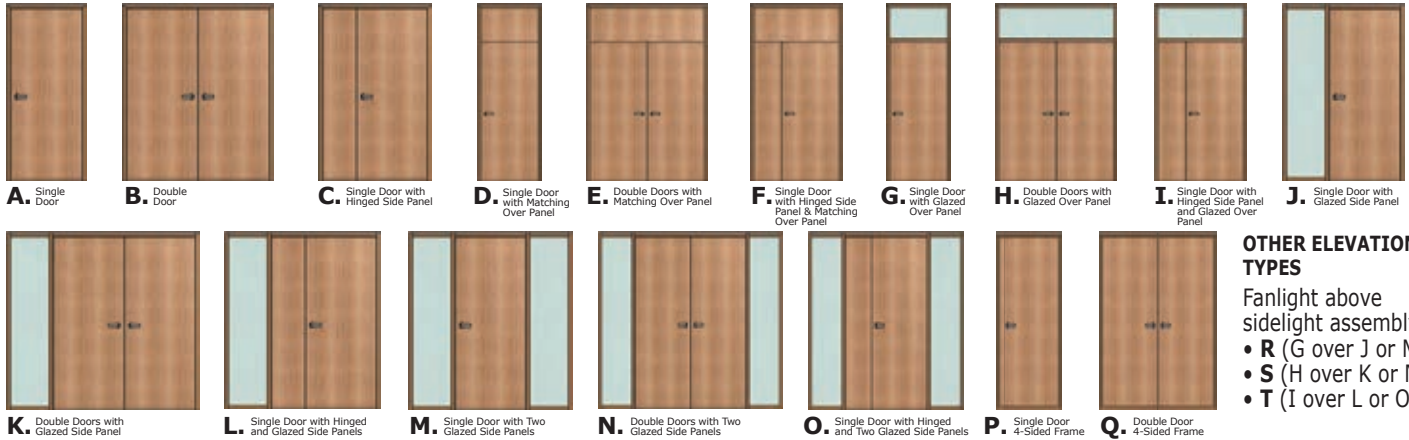

Four Sided frames for single (P) & double (Q): maximum permitted height of upstand from FFL to Cill. 900mm (such height to be inclusive of the leaf maximum permitted height). Requires additional 2 NO. 15 x 4 intumescent seal in the base of the leaf (FZD5336).

SUPPORTING CONSTRUCTION FOR TIMBER DOOR & FRAME ASSEMBLIES

The supporting construction may be timber stud & frame (FZD5317) or steel stud, head & base track (FZD5318), plasterboard partition (with plasterboard on both faces of the stud), masonry wall or FORZA timber framed glazed partition (FZD5319), but shall be of a type that has been tested or assessed to provide in excess of 60 minutes fire resistance, at the required size, when incorporating FD60 timber door assembly openings. If fitted into a proprietary demountable and relocatable partition system providing in excess of 60 minutes fire resistance the method of forming the timber door assembly aperture must be as tested by the partition manufacturer. Limitation of allowable elevations/leaf sizes and ironmongery as tested and specified by the partition manufacturer shall take total precedence over Forza data. At the threshold of the assembly a raised access floor may form part of the supporting construction instead of a masonry floor subject to the line of fire resistance beneath the raised floor shall continue in the same plane as that of the door assembly and the total floor construction achieves at least the same duration of fire resistance as that required of the assembly. The construction of the raised floor shall allow for robust fixing of the assembly and provide adequate support for the duration of the required period of fire resistance.

THE THRESHOLD

(FZD5335) under the door leaf must be formed of non-combustible materials that form part of the floor system including boards, masonry or ceramics but exclude metals. Alternatively timber thresholds may be installed to form part of the floor system, to be flush to the FFL and be a minimum 15mm thick x 72mm wide hardwood (min. density 640kg/m³). The bottom of the leaf to be fitted with additional 2 no. 15mm x 4mm intumescents (type as per vertical edges) or an automatic drop seal as detailed in note 22 lined with 2mm graphite intumescent either side of the drop seal. See Note; Gap Tolerance Leaf to Threshold.

FD60 TIMBER FRAME SPECIFICATION

Flush Timber Frame Specification FD60 - Table 11					
Material	Minimum Density @ 12% moisture content	Minimum Frame Face Width		Minimum Frame Depth	Minimum Stop Width
		Single Acting	Double Acting		
FD60 Hardwood	640kg/m ³	32mm Excl.Stop	38mm	70mm	12mm
MDF	700kg/m ³	45mm Excl.Stop	Not Permitted	70mm	12mm

Rebated Timber Frame Specification FD60 - Table 12			
Material	Minimum Density @ 12% moisture content	Minimum Frame Face Width	Minimum Frame Depth
		Single Acting Only	
FD60 Hardwood	640kg/m ³	32mm for the body of the frame, with the door mounted on a 22-24mm projection, with a 32mm deep +12mm x 12mm rebate to act as a stop	70mm

The overall frame depth may be increased either in solid form or with the use of extension linings where the joint/biscuit between the extension and the main frame, which must retain its minimum frame depth, does not intrude into the plane of the door thickness. Back to Back frames are permitted as per drawing FZD0606 @ Forza-doors.com. A transom between an overpanel and single acting door assembly shall be equal to the frame depth x 32mm thick plus a minimum 12mm thick stop on both the leaf and transom side, making a minimum 56mm thick section. For a double acting assembly the transom to be equal to the frame depth x 44mm. Joint fixing to the frame to be either butt joint, mortice & tenon or half-lapped (glued and twice screwed).

The use of Beech for Flush Timber frames has a number of limitations as to size and Ironmongery suitability. Contact the Forza Doors Technical Team: tech@forza-doors.com.

The use of Beech for Rebated timber frames is not permitted.

FD60 DOOR FRAME JOINT OPTIONS



GLUES Suitable glues for joints incorporating minimum 2 screws:

- **Cascamite** - Urea Formaldehyde Resin
- **Aerodux** - Resorcinol Resin
- **Gorilla Glue** - PVA

METAL DOOR FRAMES - SINGLE ACTING

Forza FD60 leaves are not permitted to be installed into Aluminium frames.

Forza FD60 leaves are permitted to be installed in Steel frames subject to specific limitations. Contact the Forza Doors Technical Team: tech@forza-doors.com

TIMBER FRAME INSTALLATION & GAP TOLERANCE

The frames must be fixed back to the supporting construction with steel fixings at centres not exceeding 600mm on the vertical edges (minimum 200mm from the top and bottom), and a minimum of one fitted centrally across the width of the frame head of double doors. Screws shall be of sufficient length to penetrate the supporting construction by at least 40mm, and shall be positioned centrally across the frame depth. A twin line of screws may be required depending on increased frame depths / supporting construction type. Suitably thick packers depending on frame to supporting construction gap shall be used at all fixing positions.

The gap between the frame and the supporting construction when architraves are in use shall be between 5mm and 10mm (max) enabling intumescent mastic (an approved linear gap intumescent mastic successfully tested in accordance with BS476-20 or BS EN 1366-4 for the required period of fire resistance) and mineral wool to be positioned as per drawing DRW11. The architraves (minimum thickness 15mm) of the same material as the frame to be mechanically fixed providing 15mm overlap on both frame and supporting construction (DRW11).

Forza shadow gap details may be included in the supporting construction DRW15 or in a frame extension at the interface of the frame and wall DRW16. Minimum Frame density/depths 640kg/m³/104mm for both DRW15 and DRW16.

Architraves may be omitted when Mann Mcgowan Pyromas A is the intumescent mastic positioned as per DRW11 and the frame depth is minimum 104mm.

The following expanding linear gap Fire foams are approved for use with Forza Fire Doors positioned as per DRW13:

Sealed Tight Solutions Ltd. ST99 FR Foam for gaps up to 10mm **with architraves (min 15mm thick)** and minimum frame density/depths 640kg/m³/104mm

Fire and Acoustic Seals Ltd. Fire Door Foam for gaps up to 20mm **with or without architraves** with minimum frame density/depths 640kg/m³/90mm

For Gaps to a maximum of 7mm the Forza Smart Frame with factory prepared intumescent and mineral wool applied to the back of the frame may be installed as per DRW18.

DRW11

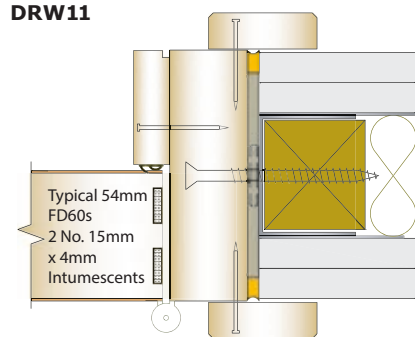

DRW13

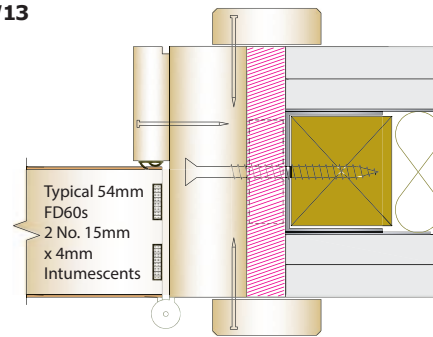

DRW15

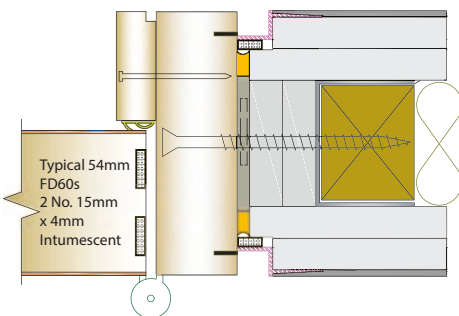

DRW16

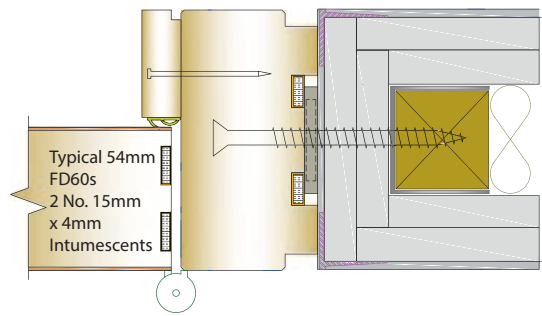



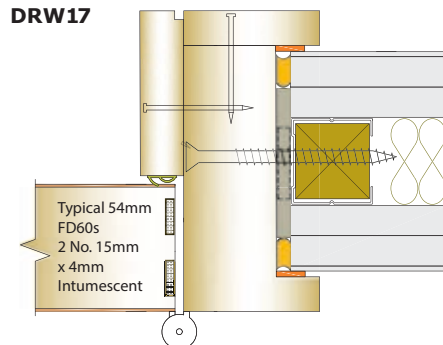



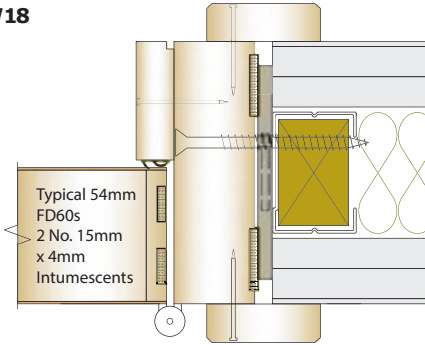



DRW17



DRW18



Key

-  Screw fixing minimum 40mm into wall struture
-  Mineral Wool fills void
-  3mm gap with ST1009 Acoustic Smoke Seal
-  Minimum 12mm thick Stop pinned to frame
-  Packer shim to match gap depth at each fixing
-  Minimum 10mm deep Intumescent Mastic applied to perimeter of frame
-  Intumescent Strips
-  Gap to be 5mm to max 20mm at structure opening when using Fire & Acoustic Seals Ltd Expanding Foam
-  10mm x 4mm Intumescent Seal bonded to back of Aluminium trim
-  10mm x 2mm Interdens
-  10mm x 2mm Graphite

For all other gaps between the frame and the supporting construction (with or without architraves) the method of installation should follow the recommendations of Tables 2 to 5 in BS 8214:2016, "Timber based fire door assemblies - Code of Practice", using fire seal products proven in linear timber applications.

No part of the rear of the frame section shall be exposed once installed except for where integral architraves DRW17 (FZD0177/1) or the above shadow gap details are utilised.

The standard door assembly design should be such that single acting leaves are within 1mm projection from the timber frame when closed and in double door assemblies the face of the leaves may be up to 1mm offset from one another at the meeting stiles when closed.

Double acting doors should be centred on the frame depth.

GAP TOLERANCE DIMENSION FOR LEAF TO FRAME & LEAF TO THRESHOLD

The gap between the door and the timber frame, double door meeting stiles, door(s) and overpanel should be between 1.5mm to 4.0 mm. The gap between the bottom of leaf and the threshold of either boards/

masonry/ceramics or timber to be maximum 10mm. In all instances where smoke control is required with no drop seal the gap should only be 3mm.

VISION PANELS (FZD0338)

Forza standard vision panel styles V1 to V9 are constructed with a laminate un-insulated fire glass (FD60/0. 12mm) with either Bolection or Quirk bead styles. The glass area in styles V1 to V8 have less than 20% of the leaf size on a 1981mm x 838mm (or greater) and are therefore deemed to be partially insulating door assemblies using the criteria given in section 7 of BS476: part22: 1987 and thus evaluated to section 7 for FD60/60 integrity and insulation. For use of Forza Style V9 or any bespoke vision panels greater than 20% of the leaf size, the intended location of the door assembly is to be considered .i.e escape routes / protected stairway (refer Approved doc B v1 & v2 table B5).

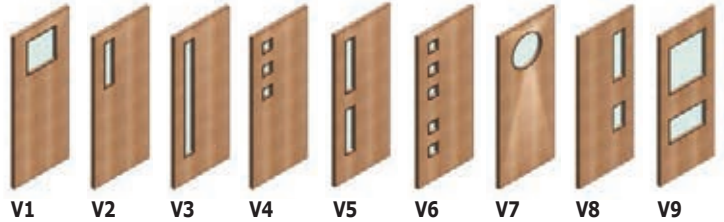

A variety of surface fixed overhead door closers (see note 6 controlled door closing devices) may be installed above vision panels V1 to V8 on either the exposed or unexposed face of the door assembly. Limitation of manufacturers/makes of surface fixed closers apply when fixed to the unexposed face of a leaf with a vision panel greater than 20% of the leaf size. (see note 6 controlled door closing devices).

On request Forza are able to supply fully insulating vision panel door assemblies with glazed areas greater than 20% of the leaf size utilizing Insulating glass types to FD60/60, 25mm.



All Forza fire rated glass panels are stencil marked with the glass make and fire rating.

Non Forza factory prepared vision panel installation or alterations are not permitted.

OVERPANELS

A single piece overpanel across the frame width shall be secured into the timber frame using steel screws fixed through the rear of the frame members, passing at least 40mm into the centre of the overpanel thickness. (Screws must not be fixed through the overpanel into the stops, or vice versa). Screws must be no more than 100mm from

each corner of the overpanel, and at maximum 400mm centres, with a minimum of 2 no. Screws per overpanel edge. This specification applies to overpanels used with or without a transom. The gap between overpanel and frame should not exceed 3mm. The overpanel must always be on the same plane as the door(s).

SINGLE CENTRE GLAZED FANLIGHTS & SIDELIGHTS

Fanlights above a transomed timber frame are permitted in elevation types G, H, I, R, S, T. Sidelights may be included in the door assembly either to one or both sides of the doorframe/mullion. The perimeter frame and head to be fixed to the supporting construction in accordance with the Forza frame installation and gap tolerance details.

The interface between the horizontal base of the side light frame and the supporting finished floor level to be intimate, secure with no gaps thus allowing for the omission at the base of a fire sealing system. For permitted fire glass aperture sizes, integrity and insulation properties contact the Forza Sales Team.

RISER DOOR(S)

Door leaves may be installed in a four sided frame (Elevation 'P' Single and Elevation 'Q' Double) with the base of the frame at a higher level than the finished floor level: maximum permitted height of upstand from FFL to Sill

900mm (such height to be inclusive of the leaf maximum permitted height). Requires additional 2 no. 15mm x 4mm intumescent seals in the base of the leaf(s). Minimum frame depth 104mm/face width 32mm.

AMBIENT TEMPERATURE SMOKE CONTROL SEALS

Forza FD60s fire door labels are affixed to the top of the door leaf when the Forza tested smoke control gasket (ST1009) is installed on the full perimeter door stop of the single/double door assembly (meeting style and overpanel edge to include single fin combined gasket).

Various manufacturers smoke seals or combined intumescent smoke seals that have been tested in accordance with BS EN 1634-3:2004 (ambient temperature) or BS476: part 31: section 31, 1:1983 and demonstrated not to leak by more than 3m³/m/hr (head and jambs only) at 25Pa, may also

be used in conjunction with Forza door assemblies to provide smoke control (Forza unable to affix an "S" label in these instances). To achieve the required level of smoke control the orientation of the seals and degree of hardware interruption, door edge gaps and leaf configuration must be as tested by the seal manufacturer. The threshold gap should where practicable be sealed by a flexible edge or automatic drop seal with a leakage rate as tested above or where this is not practicable due to the interference with the closing action of the door, the threshold gap should not exceed 3mm at any point.

INTUMESCENT GRAPHITE BASED/PVC CASED SEAL SPECIFICATION & IRONMONGERY INTERRUPTION

FD60 - Two no. 15mm x 4mm seal fitted centrally at the head and stiles in either the door leaf or the equivalent position in the frame/overpanel and in double door flush meeting stiles. Double door rebated meeting stiles & overpanel, two no. 15mm x 4mm with one in each rebate.

Intumescent seals may be partially interrupted in the leaf or frame edge by the dimensioned hinges and lock forend as per drawing DRW19. Intumescent specification & positioning for door leaves installed in Steel frames to follow installation instructions provided by the frame supplier/manufacturer.

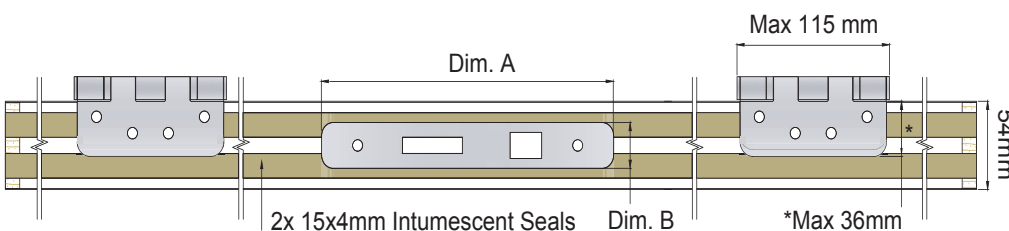

DRAWING FZD5113 (DRW19) FD60/54mm Lock Forend or Strikeplate

Dim.A=235mm x Dim.B=25mm or (Dim.A=203mm x Dim.B=28mm)

FORZA FD60 - IRONMONGERY SUITABILITY & INSTALLATION GUIDE

1. Single Axis Knuckle Hinges to BS EN 1935:2002

A variety of single axis hinges have been successfully tested with the timber door leaves within timber and steel frames. Hinges may be used, subject to compliance with the specifications below.

Hinge type: Fixed pin, washered butt, ball bearing butt, lift-off type or journal supported hinges may be used.

Number of hinges: 2no. (1Pair) per leaf on leaves up to 1981mm high. 3no. (1½ pairs) per leaf on leaves up to 2400mm high. 4no. (2 pairs) per leaf on leaves greater than 2400mm high.

Positions: The top hinge must be positioned 120-180mm down from the head of the leaf to the top of the hinge and the bottom hinge positioned 200-250mm up from the foot of the leaf to the bottom of the hinge. The middle hinge of three must be either equally spaced between the top and bottom hinge (+200mm /-0mm), or 200-250 below the top hinge. The middle hinges of four must be either equally spaced between the top and bottom hinge (+/-150mm) or 2nd hinge 200-250mm below the top hinge and 3rd hinge equally spaced between the second and fourth (bottom) hinge.

Fixings: Steel screws, as recommended by the hinge manufacturers, but in no case smaller than 32mm long x 3.8mm diameter (no.8) and having thread for the full length.

Hinge blade sizes: 2.5-3.5mm thick by 89-115mm high by 30-36mm width. (These dimensions refer to the blade size, i.e. the part of the hinges that are recessed into the edge of the leaves/frame.)

Hinge materials: Brass, Phosphor Bronze, Steel or Stainless Steel. No combustible or thermally softening materials to be included.

Intumescent protection: Hinge blades to be bedded on 1mm thick low pressure forming graphite material. Partial interruption of intumescent seals is permitted provided a minimum 10mm width of intumescent is continuous past the hardware as per DRW19. Any recess made for the installation of the hinge shall be tightly cut to the size of the blade. Rising butt, non-cranked butts and spring hinges (single or double action) are not suitable for use on Forza doors approved within FD60 PAR/10896/01 rev I, (Such hinges may be suitable on the basis of an individual and project specific fire engineering evaluation. Contact Forza Technical).

2. Concealed or Invisible Hinges (Timber frame only) (Ref. European technical assessment (ETA) EAD 0405:March 2017)

A variety of concealed or invisible hinges have been assessed for inclusion within Forza timber leaves and frames. They are:

- SOSS Invisible Hinge Type 218 (Stainless Steel) (Factory prepared leaf and frame only)
- SOSS Invisible Hinge Type 418 (Stainless Steel) (Factory prepared leaf and frame only)
- Tectus Concealed Hinge Type TE526 3d (Stainless Steel) (Factory prepared leaf and frame only)
- Tectus Concealed Hinge Type TE540 3d (Aluminium & Zinc Alloy) (Factory prepared leaf and frame only)

These hinges may be included in door assemblies subject to compliance with the specification below:

- Screws supplied by the Hinge manufacturer must be used
- Timber frame (640kg/m³) to have minimum 45mm face width.
- The correct number of hinges are fitted as recommended by the hinge manufacturer, to ensure that the door leaf is supported for the full fire resistance period.
- The slots for the hinges in the door leaf and frame must be cut tightly, such that there are no gaps around the hinge components / intumescent material when the hinges are installed.
- Hinge positions to be set 120-180mm down from leaf head to top of hinge, 200-250mm up from bottom of leaf to bottom of hinge blade third hinge set 200-250mm below top hinge. Additional hinges equi-spaced.
- All hinge positions must be fitted with intumescent gasket kits supplied by the hinge manufacturer (as per test evidence for the hinge type).

At least 10mm width of intumescent strip must be continuous past the hinge edge and stop. Concealed hinges are Not permitted with shadow gaps detailed in DRW15 or DRW16.

3. Mechanically Operated Mortice Locks/Latches to BS EN 12209:2016 (Timber or Steel frames)

A variety of mortice locks/latches may be used, subject to compliance with the specifications below:

Latch/lock types: Mortice latches, tubular mortice latches, sashlocks and deadlocks (cylinders to comply to BS EN 1303)

Positioning: Centred at 1000mm (±400mm) above the bottom of the door leaf.

Maximum dimensions: Timber frames

- **Forend plate:** 235mm long x 25mm wide or 203mm long x 28mm wide (see additional protection)
- **Latch body:** 20mm thick x 165mm high x 100mm wide (See additional protection)
- **Strikeplate:** 235mm long x 25mm wide or 203mm long x 28mm wide (see additional protection)

Maximum dimensions: Metal frames (See additional protection)

- **Forend plate:** 158mm long x 25mm wide
- **Latch body:** 16mm thick x 108mm high x 74mm wide
- **Strikeplate:** 98mm long x 26mm wide

Materials: Steel based with no essential part of the structure made from polymeric or other low melting point (<800°C) materials, and should not contain any flammable materials.

Additional protection: Timber frame: The mortice for the lock body to be lined and the strikeplate / forend to be bedded on low pressure forming intumescent sheet at least 1mm thick (e.g Interdens).

Steel frame: 1mm interdens on all faces of latch body and under forend. 2mm Therm-A-Flex under strike plate and lining strike box.

Over-morticing is to be avoided: Mortices should be as tight as possible to the latch. If gaps occur around the case (not exceeding 2mm), then these must be made good with intumescent mastic or sheet material. Holes for spindles or cylinders should be kept as small as is compatible with the operation of the hardware.

Glazing apertures: Where glazing apertures are also incorporated and are positioned such that locks/latches are included in the margin between the aperture and door edge the inner back of the mortice must be at least 50mm from the edge of the aperture. If the mortice latch/lock is fitted in line with a 'rail' between two apertures, no part of the lock mortice shall be closer than 50mm to the edge of any aperture.

4. Multi-Point Locking Systems (Timber frame only) (Ref. Pr EN 15685)

A range of Forza factory prepared Multi-Point locking systems are permitted for F60 single door assemblies in timber frames. Contact tech@forza-doors.com

5. Mechanical Digital Locks to BS8607 :2014/16 (Timber frame only)

Securefast SBL320 Keypad: H158mm x W45mm. The keypad may fitted to the exposed or unexposed face of the leaf.

Securefast SBL330 Keypad: H142mm x W41mm & **SBL365** Keypad H178mm x W48mm. The keypad to be fitted to the known exposed face only.

Protection: latch body/ forend /strike box to be wrapped/lined in 1mm thick Interdens.

6. Controlled Door Closing Devices to BS EN 1154:1997

Where required by regulatory guidance or specific fire strategy each hinged door leaf must be fitted with a self-closing device unless it is normally kept locked shut and labelled as such with an appropriate sign which complies with BS5499-10:2014. It is essential that all closers fulfil the requirements of BS EN 1154: 1997 and are of the correct power rating for the width and weight of the door(s) (minimum power size 3).

The Closer must be fitted according to the manufacturer's instructions and be adjusted so that it is capable of fully closing the door leaf, against any friction imposed by the latch (and smoke seals if fitted) from any position of opening.

Face Fixed: (Timber or Steel frames) A variety of Surface mounted overhead door closers (and accessories such as soffit brackets) that have been tested, assessed or otherwise approved for use on unlatched FD60 timber door leaves in timber or steel frames may be fixed to the exposed or unexposed face of a Forza flush door leaf or vision panelled leaf where the glazed element is 20% or less than the leaf size. Any accessory that is located within the door reveal must have appropriate test or assessment evidence by the closer manufacturer. The following closers may be installed on the exposed or unexposed face of a Forza vision panelled leaf where the glazed element comprises 12mm partially insulating glass up to 50% of the leaf size.

- Hoppe AR5500SD or AR9500SD

Concealed overhead: (Timber frame only) Several types of concealed overhead closers are suitable for inclusion in Forza timber door & frame assemblies as listed overleaf. These are a 'slide arm' type closers with the closer morticed into the head of the leaf and a single arm and roller acting in a slide channel morticed into the frame head.

Door Closers (continued)

- Dorma ITS96 (power 2-4 model)
- Dorint TC320 (power 2-4 model)
- Synergy S1000 (power 2-4 model)
- Rutland ITS.11204 (power size 2-4)
- Synergy S1036 (power 3-6 model).

These closers have been tested by their manufacturers and subject to the limitations below may be used.

- Minimum stop depth at the head as stipulated by the closer manufacturers tested instructions.
- Inclusion of intumescent gasket kit as tested and supplied by the closer manufacture.
- A minimum of 10mm width of intumescent must be residual alongside the arm recess in the head of the frame or an additional 10 x 2mm strip of graphite intumescent strip must be included in the slide arm channel in the head of the frame.

The body of the concealed closer is not to be fitted in the frame head. Other makes of concealed closers may be suitable for use in leaves approved within the scope of the Forza certification but on the basis of an individual and specific fire engineering evaluation. Contact: tech@forza-doors.com

Concealed Jamb: (Timber frame only) The Perko Powermatic concealed jamb closer R108 is suitable for inclusion in factory prepared Forza door and timber frame assemblies.

- Protection: The manufacturers intumescent Kit installed as per instructions.
- Maximum height position 1000mm from bottom of leaf to its centre.
- The top/bottom of the closer to be positioned at least 150mm from any hinges.
- Timber frame to have minimum 45mm face width.
- Concealed hinges are not permitted to be used when a Perko R108 is fitted.

Jamb mounted closers are not approved for use with door assemblies comprising of steel frames.

Floor Springs and Accessories: (Timber frame only) Floor springs and accessories may be used, subject to having the manufacturers product fire test or assessment evidence for use on timber door & frame assemblies of similar construction and thickness to that being installed, and the following limitations;

- Incorporation of any intumescent jacket/gaskets used in the test and supplied by the manufacturer;
- Continuation of at least 20mm (total width) of the intumescent edge seals in leaf or frame head (as applicable); either 10mm along both sides of the top strap/pivot for double acting straps, or 20mm on one side for single acting straps;
- Minimum 1mm thick intumescent sheet (e.g. Interdens) must line the mortise of the top strap and pivot in both the door leaf and frame head (or as supplied by the floor spring manufacturer);
- No removal of the timber or intumescent strip at the leaf stile (except for a 6-8mm diameter access hole for the top strap adjustment screw).

7. Electrically Powered Hold Open Devices to BS EN 1155:1997 (Timber or Steel frames)

Fully surface mounted hold open devices may be installed on leaves subject to:

- Maximum footprint of device on leaf 100mm x 100mm.
- Position to be a minimum 150mm from any glazed aperture.
- No cableway required within the door leaf.

8. Electrically Controlled Exit Systems to BS EN 13637:2015

For suitability of installation contact the Forza Doors Technical Team: tech@Forza-Doors.com

9. Power Operated Pedestrian Door Devices to BS EN 16005:2012

For suitability of installation contact the Forza Doors Technical Team: tech@forza-doors.com.

10. Double Door Sequence Selectors to BS EN 1158:2002 (Timber or Steel frames)

Face fixed door sequence / co-ordinators that fulfil the requirements of BS EN 1158 are permitted for use on double leaf door assemblies with rebated meeting stiles, to ensure that the leaves close in sequence. Door selectors must not be recessed into the leaf or frame and must not intrude into the door edge interface or interrupt any intumescent strips.

11. Cableway and Cable Loop (Timber frame only)

A Cableway and cable loop to provide a route for the connection of electric locks/strikes with command units are permitted subject to the following:

Permitted cable loops: Assa Abloy EA280, AE281, Securefast ALP101

- The device must be fitted precisely in accordance with the manufacturer's installation instructions.
- The door leaf rebate to be centrally positioned to accept the cable loop box and to be lined with a minimum 2mm thick graphite based (eg STS302) intumescent liner.
- The cover plate for the hole in the frame to be bedded on 2mm graphite based intumescent liner.
- The cableway may be incorporated in the door leaf in one of the following methods:
 - A. A maximum of 10mm diameter hole drilled centrally in the door thickness and horizontally across the width of the door at a height of not more than 1200 mm above finished floor level and lined with a 10mm x 1mm STS Cablepro intumescent tube. The cableway must be located to provide for a minimum margin of 100 mm from any aperture in the door leaf.
 - B. Forza factory prepared 64mm leaf for positioning around a vision panel.

12. Electronic Locks & Magnetic Locks (Timber frame only)

Positioning of lock recess / holes / intumescent and permissible leaf sizes as per Forza FZD drawings are available on the Forza website or contact: tech@forza-doors.com.

Electronic Locks to BS EN 14846:2008: A range of electronic locks incorporating battery / keycard reader / mobile access board and or key cylinder are suitable for inclusion in Forza door assemblies on the exposed or unexposed leaf face as listed below and detailed in the noted Forza drawings.

- Assa Abloy Vingcard Essence RFID V2 (FZD5333) FD60 54mm thick leaf
- NSP SMF Duo (FZD5324) FD60 54mm thick leaf
- Salto XS4 (FZD5322) FD60 54mm thick leaf
- NSP 613/614 MiFare (FZD5323) FD60 54mm thick leaf
- Assa Abloy 351U80 & 351M80 Drop bolt (FZD5329) FD60 54mm thick leaf
- Onity Advance Trillium RFID + Euro 5470H (FZD5325) FD60 54mm thick leaf
- Assa Abloy EL560 (FZD5328) FD60 54mm thick leaf

Electromagnetic Locks: (Ref. Door Hardware Federation - DHF TS 010 :2016/19).

The lock body must have no essential part of the structure made from polymeric or other low melting materials and not contain any flammable material.

A variety of bolt through (via a security cylinder) maglocks (FZD5327) may be through fixed onto the door leaf(s) subject to the following conditions:

- Positioning: armature plate to be a minimum 70mm from leading edge of leaf and minimum 10mm from the head of leaf, maglock fixed to frame to engage with armature plate.
- Maximum dimension of armature plate: L185mm x H61mm x 16mm Thick
- Maximum dimension of maglock body: L288mm x H73mm x 40mm Thick
- Security Cylinder: maximum 12mm diameter surrounded by 1mm graphite intumescent.

A variety of face fixed maglocks (FZD5326) may be installed onto the door leaf(s) subject to the following conditions:

- Positioning: armature plate face fixed to be minimum 70mm from leading edge of leaf and minimum 10mm from head of leaf, maglock fixed to frame to engage with armature plate.
- Maximum dimension of armature plate: L200mm x H61mm x 16mm Thick
- Maximum dimension of maglock body: L305mm x H76mm x 44mm Thick

Face fixed maglocks may be installed with Z or L brackets. Bolt through and face fixed maglocks may be installed on the exposed or unexposed leaf face.

Electronic Digital Locks to EN 16867:2020/21

- Codelocks CL5010 with lever handle (FZD5331): Keypad H198mm x W70mm, Strike plate 57mm x 31mm
- Codelocks Cl2255 with lever handle (FZD5332): Keypad H141mm x W41mm, Strike plate 57mm x 31mm

The keypad to be fitted to the known unexposed face only.

1mm Interdens around the 20mm /25mm diameter holes. Pyroplex intumescent sealant around the 8mm holes.

13. Bolts for Inactive or Slave Leaves to BS EN 12051:2000 (Timber or Steel frames)

Bolts are not necessary for Forza FD60 double doors. However, the extra restraint provided by bolts does have a beneficial effect. Unless Specific fire test evidence is available for use on timber doors and frames, all bolts shall be steel. The following limitations and protection apply;

- Maximum size of flush bolt is 457mm long x 20mm wide and 25mm deep (relates to the deepest element of the bolt when in operation);
- The head of the leaf and/or frame should contain intumescent material local to the bolt/keep plate;
- The body of the bolt should be bedded on non-pressure forming intumescent material (e.g. Interdens) at least 1mm thick;
- Edge fixed bolts shall be positioned centrally in the slave leaf thickness with the meeting style intumescent in the active leaf.
- Flush bolts are not permissible on doors with rebated overpanels, since this will clash with the rebate alignment. Surface mounted bolts may be used; see below;
- Face fixed flush bolts shall be fixed so that there is a minimum of 50mm between the bolt and the door edge;
- Surface mounted barrel bolts shall not exceed 400mm in length, but there is no limitation on their width. Screws for fixing bolts must be at least 25mm long, and have thread for the full screw length. They shall be fixed so that there is a minimum of 50mm between the bolt and the door edge.

14. Pull Handles to BS 8424:2004 (Timber or Steel frames)

Pull Handles of varying length may be fixed to the door assemblies with multiple fixing points provided that the outer fixing points are no greater than 1500mm apart. Pull handles that are fixed through the leaf (steel fixings only) should use clearance holes as close fitting as possible to the bolt. Handles / fixings to be at least 40mm from door edge and any aperture.

15. Lever Handles & Knob Furniture to BS EN 1906:2012 (Timber or Steel frames)

Traditional mechanical metal/alloy lever handles not containing any flammable materials are suitable for Forza door leaves. Holes through the leaf shall be as tight as possible to the spindle. Fixing screws must be steel. Where leaves contain vision panels the fixing screws shall be at least 35mm from the visible edge of the glazing bead.

16. Emergency Exit Devices to BS EN 1125:2008 (Horizontal Bar) & BS EN 179:2008 (lever handle or push pad) (Timber or Steel frames)

Panic hardware may be surface mounted to door leaves provided that the installation does not require the removal of any core material from the door leaf. The panic hardware must not in any way interfere with the self-closing action of the fire door.

17. Push / Kick Plates (Timber or Steel frames)

Plastic, pvc or metal plates may be surface-mounted to the door assemblies, but, if more than 800mm in length by nominally 200mm wide, they must be attached in a way that would prevent them distorting the door leaf, e.g. glued with thermally softening adhesive or screwed with maximum 12mm long screws at minimum 250mm centres and fitted in such a way so they will not be prevented from falling away by being trapped under door stops, glazing beads or handle escutcheons. Factory prepared recessed plates are permitted. Contact: tech@forza-doors.com

18. Identification Plates to BS EN 5499-4 2013 (Timber or Steel frames)

Plastic or metal safety signs that comply with BS5499 may be glued or screwed to the face of the door leaf. A minimum 40mm spacing from leaf edge, hardware or vision panel(s) is required.

19. Letter Plates (Ref. DHF TS008:2015)

(Timber or Steel frames)

Various manufacturers' letterboxes/plates that have been tested and assessed for the required period of integrity for use in 54mm thick timber FD60 doors may be installed. They must be fitted in accordance with the manufacturer's instructions, including all intumescent liners and flaps. Plates must not be less than 100mm away from the leaf edge, or any other aperture. Positioning above the finished floor level will depend upon the test evidence for the letterbox/plate.

20. Security Viewers (Ref. DHF TS002 :2009)

(Timber or Steel frames)

Door security viewers may be installed subject to the following limitations:

- Viewers must not exceed 15mm diameter, and be made from brass or steel case with a glass lens;
- Holes bored through the door must be no greater than 1mm larger than the bore of the viewer and must be lined with 1mm Interdens sheet;
- The viewer must include an effective shutter/cover plate.

Viewers shall be a minimum 40mm from the door edge and any aperture. Multiple viewers may be installed subject to the following locations:

- Top security viewer: 1500 +/- 200mm from bottom of leaf
- Lower security viewer: 1050mm +/- 200mm from bottom of leaf
- Minimum space between viewers 200mm

21. Security Magnetic Opening Contacts to EN50131-2-6(5-3) (Timber frames only)

The DC 107, 124, 125, 887 and 888 recessed magnetic contacts by Carrier Fire & Security Ltd. are permitted for inclusion in Forza door assemblies. Plugs to be fitted central to the leaf thickness and bedded in intumescent mastic (FZD5334). Leaf Plug L. 40mm x Dia. 22mm. Frame plug L.29mm x Dia. 22mm. Frame cableway hole max. Dia.10mm and lined with intumescent mastic.

22. Automatic Threshold Dropseals (Timber or Steel frames)

The following dropseals may be morticed centrally into the base of Forza door leaves lined with 2mm graphite intumescent either side of the drop seal:

- Sealed Tight Solutions ST422
- Lorient IS8001
- Norseal NOR810S

Surface mounted threshold seals are not permitted.

23. Intumescent Air Transfer Grilles to BS EN 1364-5:2017 (Timber or Steel frames)

Fire / Fire & cold smoke containment air transfer grilles tested and assessed for the required period of integrity are permitted for use with 54mm thick timber FD60 doors. They must be fitted fully in accordance with the grille manufacturer's instructions, including all intumescent liners, cloaking grilles/beads, (wire way as per note 11) and must be no larger than that for which test or assessment evidence exists.

The maximum combined aperture size for vision panels and air transfer grilles within a single leaf shall not exceed 0.5 m². Forza minimum edge distance for apertures shall take precedence when fitting air transfer grilles i.e from bottom edge of leaf: 200mm, top and side edges of leaf 150mm and between apertures 120mm.

24. Finger Trap Protection Devices to BS 8613:2017

For suitability of installation contact the Forza Doors Technical Team: tech@Forza-Doors.com

FD60 PERMISSIBLE ONSITE TIMBER LEAF/FRAME DOOR ASSEMBLY REPAIRS & LEAF SIZE ADJUSTMENT (FZD5136)

Each vertical leaf edge should not be reduced for site tolerance by more than 2mm with hinge or intumescent recesses re-depthed accordingly. Resizing of leaf(s) height from the base of the door(s) is permissible subject to maintaining permitted ironmongery and vision panel position dimensions in relation to the base of the door.



R1. Door leaf lipping
At locations where hinges have been removed or relocated in leaf or frame the redundant recess (max dim: 110mm x 36mm x 3.5mm) may be fully filled with a timber of a minimum density 640Kg/m³. Glue as recommended.

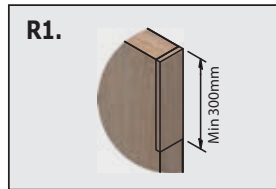

Door leaf lippings may be repaired at any position of the leaf edge with a 300mm minimum length section of timber (min density 640Kg/m³) of equal depth to the door leaf. The repair timber to have square ends, butt jointed to the existing lipping. Glue as recommended.

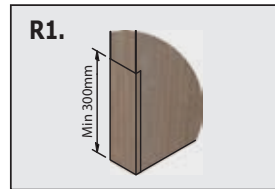

As an alternative the full length of the lipping may be repaired. Intumescent seals to be fully reinstated at the position of repair, butt joint and free from gaps with existing seals.

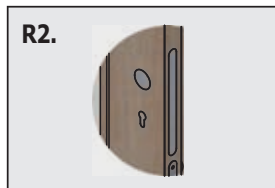

R2. Mortice for latches/locks Maximum mortice recess of 165mm x 96mm x 20mm may be infilled with timber (min density 640Kg/m³). Lipping/intumescent reinstated. Glue as recommended.



R3. Shoot bolt adjustment, removal or relocation Maximum 456mm x 8mm wide x 19mm shoot bolt recess at top or bottom of leading edge in passive leaf double door assembly may be infilled with timber (min density 640Kg/m³). Lipping/intumescent reinstated. Glue as recommended.

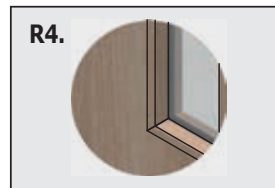

R4. Glazing beads Repair with the same timber and dimension bolecion or quirk bead is permitted. Joint between existing bead opposing end to be square with corner joint mitred. Pinned or screwed. Glazing gasket to be repositioned.

Repairs Recommended Glue

- Cascamite - Urea Formaldehyde Resin or
- Aerodux - Resorcinol Resin

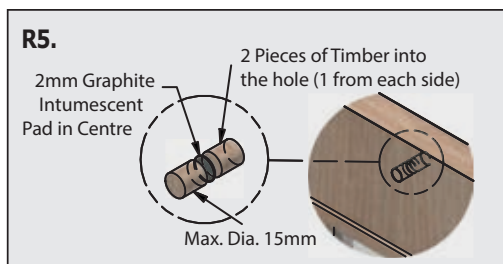
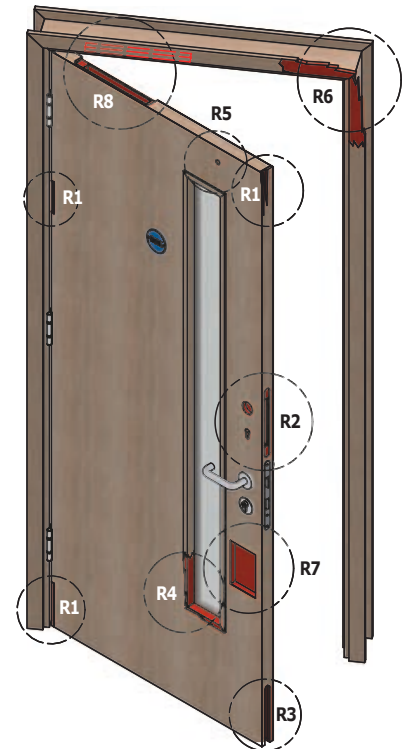

R5. Through fixings removed or relocated Maximum diameter 15mm timber (minimum density 640Kg/m³) two part infill dowel, with centred 2mm graphite pad, installed to the full depth of the leaf. Glue as recommended.

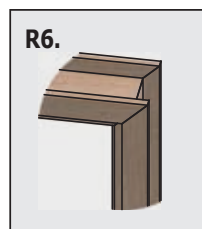

R6. Architrave Repair with same timber and dimension of existing architrave. Joint between existing architrave to be square cut with corner joint mitred. Pinned to wall/frame.

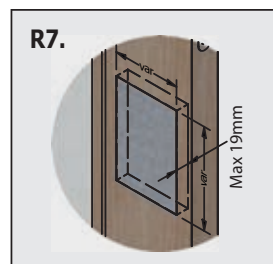

R7. Leaf face recess re-instated Maximum size timber (640kg/m³) face plate infill: 200mm high x 100mm wide x 19mm deep.

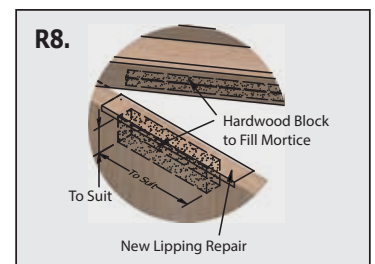

R8. Concealed closer mortice re-instated Maximum size timber (640Kg/m³): leaf closer body infill; L 338mm x H 47mm x W 35mm. Lipping; L 575mm x H 8mm x W 44/54mm. Frame slide arm infill; L 448mm x H 22mm x W 35mm.

REPAIR	DATE:	TYPE (R?):	NOTE:
	DATE:	TYPE (R?):	NOTE: