

Environmental Product Declaration



THE INTERNATIONAL EPD SYSTEM



In accordance with ISO 14025:2006 and EN 15804:2012+A2:2019/AC:2021 for:

H-beam

from

Dongkuk Steel



Programme:	The International EPD® System, www.environdec.com
Programme operator:	EPD International AB
EPD registration number:	S-P-11678
Publication date:	2024-01-12
Valid until:	2029-01-12

An EPD should provide current information and may be updated if conditions change. The stated validity is therefore subject to the continued registration and publication at www.environdec.com



General information

Programme information

Programme:	The International EPD® System v4.0
Address:	EPD International AB Box 210 60 SE-100 31 Stockholm Sweden
Website:	www.environdec.com
E-mail:	info@environdec.com

Accountabilities for PCR, LCA and independent, third-party verification
Product Category Rules (PCR)
CEN standard EN 15804 serves as the Core Product Category Rules (PCR)
Product Category Rules (PCR): Product Category Rules for Construction Products (PCR 2019:14) version 1.3.1 and UN CPC code: 41211(Flat-rolled products of non-alloy steel, not further worked than hot-rolled, of a width of 600 mm or more)
PCR review was conducted by: The International EPD® System Technical Committee Visit www.environdec.com for full list of members. Chair of the PCR review: <i>Claudia A. Peña, University of Concepción, Chile.</i> The review panel may be contacted via info@environdec.com
Life Cycle Assessment (LCA)
LCA accountability: <i>Yoosung Park, H.I.Pathway Co.,Ltd.</i>
Third-party verification
Independent third-party verification of the declaration and data, according to ISO 14025:2006, via: <input checked="" type="checkbox"/> EPD verification by accredited certification body Third-party verification: <i>Noh-hyun Lim, Certiquality Srl</i> is an approved certification body accountable for the third-party verification The certification body is accredited by: <i>Accredia</i>
Procedure for follow-up of data during EPD validity involves third party verifier: <input checked="" type="checkbox"/> Yes <input type="checkbox"/> No

The EPD owner has the sole ownership, liability, and responsibility for the EPD.

EPDs within the same product category but registered in different EPD programmes, or not compliant with EN 15804, may not be comparable. For two EPDs to be comparable, they must be based on the same PCR (including the same version number) or be based on fully-aligned PCRs or versions of PCRs; cover products with identical functions, technical performances and use (e.g. identical declared/functional units); have equivalent system boundaries and descriptions of data; apply equivalent data quality requirements, methods of data collection, and allocation methods; apply identical cut-off rules and impact assessment methods (including the same version of characterisation

factors); have equivalent content declarations; and be valid at the time of comparison. For further information about comparability, see EN 15804 and ISO 14025.

Company information

Owner of the EPD: DONGKUK STEEL MILL CO., LTD.

Contact: Yushin Kim, e-mail: yushin.kim@dongkuk.com, tel: +82 2 317 1069

Description of the organisation:

Dongkuk Steel stands at a critical juncture in its 69-year history.

To achieve sustainability, we have contemplated the various paths and growth engines that will put us on the course for future survival and prosperity. And we found the answer. That is the transition to a holding company structure and the restructuring of operating companies. The holding company will serve as the control tower for the group, developing growth strategies and concentrating on creating new business portfolios. Our primary objective is to augment the competitive edge of our core business, the steel business, through strategic investments in steel-related materials, components, and equipment. Furthermore, we endeavor to identify and pursue new business opportunities that can anticipate and shape future trends. The operating companies will redouble their efforts to improve the performance of the steel business by sharpening the fundamental competitiveness of the hot rolled businesses. Particularly in the hot-rolled business, we will pursue green growth on the basis of electric arc furnace, which has lower environmental impact. We will earnestly execute our three key tasks; energy conversion, process technology innovation, and green product portfolio development. To achieve our goals, we plan to sell more premium products, develop green products, and expand our market to include B2C customers.

To ensure future sustainable growth, we will consolidate our ESG management system and sharpen our execution capabilities.

Aiming to address the climate crisis and become an environmentally friendly company, we devised a mid- to long-term roadmap to achieve net-zero by 2050. By leveraging our extensive technological capabilities, we determined next step, and that is to develop 'future-oriented electric arc furnace' process technology. We also accomplished concrete results such as the installation of solar power generation facilities at Pohang Works. In the societal sphere, we have established a human rights management system, and conducted surveys to listen to our employees' voices, regarding our employees as overarching stakeholders. With a firm belief that the growth of our employees goes hand in hand with corporate competitiveness, we have refined the infrastructure of Hoo-in-won, our HRD center, and upgraded educational programs with the aim of encouraging our employees' growth mindset. Efforts are also being made to promote diversity as well as to create a work environment conducive to our employees. We also made remarkable progress in the aspect of governance. We laid the foundation for board-driven responsible management. For example, we secured diversity in the composition of non-executive directors, and put in place systems that enables our board to seamlessly review business performance and risk management. In the years to come, Dongkuk Steel will reach out to all stakeholders, including customers, employees, partner companies, investors, and local communities, for their opinions, and go the extra mile to unlock our value, 'Steel for Green'

Product-related or management system-related certifications: ISO 9001- and 14001-certificates

Name and location of production site(s): Dangjin factory of Dongkuk Steel, 25, Godae Industrial Complex 1-gil, Songak-eup, Dangjin-si, Chungcheongnam-do

[Overview]

Name Dongkuk Steel Mill Co., Ltd. Establishment July 7, 1954

President Choi Sam-young

Website www.dongkuksteel.com Category Mid-sized and listed enterprise (KOSPI 460860)

Head office 19, Euljiro 5-gil (Ferrum Tower, Suha-dong), Jung-gu, Seoul

Business Manufacturing and sale of hot-rolled steel plates products, reinforcing bars, sections, steel plates etc.

Product information

Product name: H-beam

Product identification: The CEN standard EN 15804:2012+A2:2019 serves as the core PCR. In addition, PCR 2019:14 Construction products (EN 15804:A2) (1.3.1) and the EN 10204

Product description:

Consisting of a wide and thick flange and a thin web, H-Beam has the excellent performance of its cross section, and features easy combination and joint so that it is widely used for structures. A wide section is good for columns.

UN CPC code: 41251

Geographical scope: The product is produced at the Pohang Factory (195 Cheolgangsandan-ro, Daesong-myeon, Nam-gu, Pohang-si, Gyeongsangbuk-do) located in Rep. of Korea. Product use was excluded from the scope of environmental impact calculations in this study. For the end of life stage, the environmental impact was calculated based on product disposal statistics from the World Steel Association, 2020.

Product identification:

Nominal Size (mm)	Sectional Area (cm)	Unit Weight (kg/m)	Moment of Inertia (cm)		Radius of Gyration (cm)		Modulus of Section (cm)	
			I _x	I _y	i _x	i _y	Z _x	Z _y
100 × 100	21.9	17.2	383	134	4.18	2.47	76.5	26.7
125 × 125	30.31	23.8	847	293	5.29	3.11	136	47
150 × 75	17.85	14	666	49.5	6.11	1.66	88.8	13.2
150 × 100	26.84	21.1	1,020	151	6.17	2.37	138	30.1
150 × 150	40.14	31.5	1,640	563	6.39	3.75	219	75.1
200 × 100	27.16	21.3	1,840	134	8.24	2.22	184	26.8
200 × 150	39.01	30.6	2,690	507	83	3.61	277	67.6
200 × 200	63.35	49.9	4,720	1,600	8.62	5.02	472	160
250 × 125	37.66	29.6	4,050	294	10.4	2.79	324	47
250 × 175	56.24	44.1	6,120	984	10.4	4.18	502	113
250 × 250	92.18	72.4	10,800	3,650	10.8	6.29	867	292
300 × 150	46.78	36.7	7,210	508	12.4	3.29	481	67.7
300 × 200	83.36	65.4	13,300	1900	12.6	4.77	893	189
300 × 300	119.8	94	20,400	6,750	13.1	7.51	1,360	450
350 × 175	63.14	49.6	13,600	984	14.7	3.95	775	112
350 × 250	101.5	79.7	21,700	3,650	14.6	6	1,280	292
350 × 350	173.9	137	40,300	13,600	15.2	8.84	2,300	776
400 × 200	84.12	66	23,700	1,740	16.8	4.54	1,190	174
400 × 300	136	107	38,700	7,210	16.9	7.28	1,980	481
400 × 400	218.7	172	66,600	22,400	17.5	10.1	3,330	1,120
450 × 200	96.76	76	33,500	1,870	18.6	4.4	1,490	187
450 × 300	157.4	124	56,100	8,110	18.9	7.18	2,550	541
500 × 200	114.2	89.6	47,800	2,140	20.5	4.33	1,910	214
500 × 300	163.5	128	71,000	8,110	20.8	7.04	2,910	541
600 × 200	134.4	106	77,600	2,280	24	4.12	2,590	228
600 × 300	222.4	175	137,000	10,600	24.9	6.9	4,620	701
700 × 300	235.5	185	201,000	10,800	29.3	6.78	5,760	722

In addition to products with the above specifications, H-beam products produced at the Pohang Plant is included.

LCA information

Functional unit / declared unit: 1 metric ton (1,000 kg)

Reference service life: Not applicable

Time representativeness: The production data are from 2022, and the database data are from 2022 i.e., no data is older than 10 years.

Database(s) and LCA software used: Database used is mainly Ecoinvent 3.9.1. The LCA software used is SimaPro 9.5.0.1

Description of system boundaries:

LCA is made in “Cradle to gate (A1–A3)” form. All major materials, production energy use and waste are included for product stages A1, A2 and A3. The product is a H-beam. After the customer purchases the product, it is manufactured as a construction product and then applied to the construction site, so, Dongkuk Steel does not have control over subsequent processes, and the usage data for each sector to which certified products are applied is not managed. Therefore, the installation (A4-A5) and use(B1-B7) are not the responsibility of Dongkuk Steel. All life cycle impacts are included, see flowchart below. The following information describes the scenarios in the different modules of the EPD. All major raw materials and all the essential energy are included. All raw material and energy flows were included in the environmental impact assessment.

System diagram:

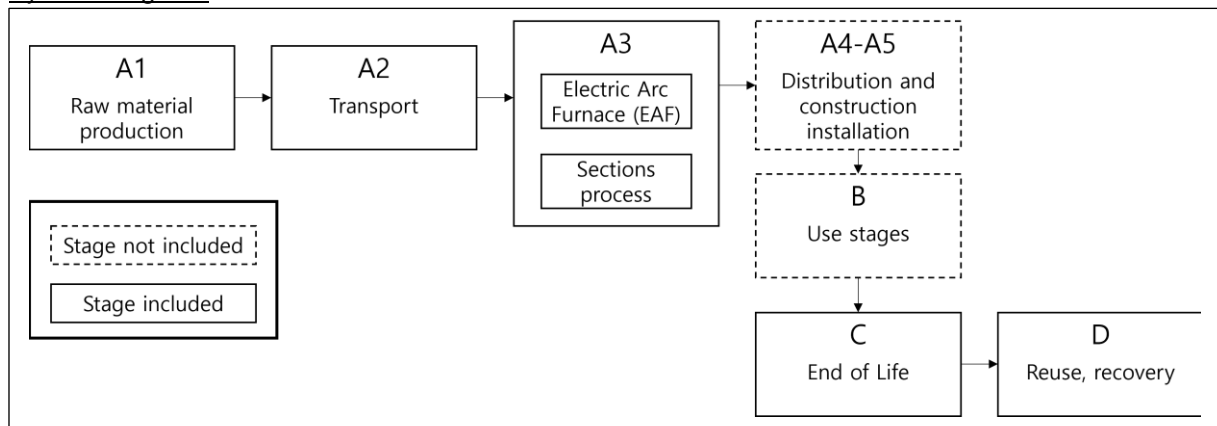

More information: Electricity, waste and ancillary materials in production are calculated as an average weight per produced tonne of all products using yearly production data and the rate for 2022. For manufacturing processes, the specific country mix of electricity is considered. For secondary data on materials’ flow information has been gathered from the Ecoinvent 3.9.1. database. In addition, the allocation is made following the provisions of PCR 2019:14 Construction products (EN 15804:A2) (1.3.1). The transportation of the material is considered in this analysis. The polluter pays and modularity principles are followed. The processes excluded from analysis are environmental impacts from infrastructure, construction, production equipment, and tools that are not directly consumed in the production process and personnel-related impacts.

	Product stage			Construction process stage		Use stage							End of life stage				Resource recovery stage
	Raw material supply	Transport	Manufacturing	Transport	Construction installation	Use	Maintenance	Repair	Replacement	Refurbishment	Operational energy use	Operational water use	De-construction demolition	Transport	Waste processing	Disposal	Reuse-Recovery-Recycling-potential
Module	A1	A2	A3	A4	A5	B1	B2	B3	B4	B5	B6	B7	C1	C2	C3	C4	D
Modules declared	X	X	X	ND	ND	ND	ND	ND	ND	ND	ND	ND	X	X	X	X	X
Geography	RoW	RoW	KR	ND	ND	ND	ND	ND	ND	ND	ND	ND	GLO	RER	RoW	RoW	RoW
Specific data used	> 90%			-	-	-	-	-	-	-	-	-	-	-	-	-	-
Variation – products	Not relevant			-	-	-	-	-	-	-	-	-	-	-	-	-	-
Variation – sites	Not relevant			-	-	-	-	-	-	-	-	-	-	-	-	-	-

X = declared stage, ND = Not Declared

- Raw material supply (A1)

The material that is needed to produce 'H-beams' products is mostly billet. Pohang factory operate steel making process through electric arc furnace.

- Transport (A2)

Transportation distance information is listed in below table.

Materials	Foreign countries distance (km)	Shipping distance (km)	Domestic distance (km)
Billet	463.33	607.75	28.10
Iron scrap (domestic)			37.91
Iron scrap(import)	51.37	681.61	12.80
Pig iron	2089.84	920.62	21.40

- Manufacturing (A3)

The processes that are included in the manufacturing phase are the steel making/casting and section processing, of which energy consumption, auxiliary material consumption, waste and gaseous emissions have been modeled.

The manufacturing process of module A3 is Rep. of Korea, and the environmental impact was calculated using the "Electricity, medium voltage {KR} | market for electricity, medium voltage | Cut-off" LCI database of Ecoinvent v3.9.1. Its climate impact is 7.00E-01 kgCO₂-eq./kWh of GWP_{total}. (GWP_{fossil})

= 6.97E-01 kgCO₂-eq./kWh, GWP_{biogenic} = 2.94E-03 kgCO₂-eq./kWh, GWP_{luluc} = 3.71E-04 kgCO₂-eq./kWh)

During the manufacturing process, there is created metal waste - 100% of metal wastes are recycled.

- De-construction demolition (C1)

Energy consumption of a demolition process is on average 10kWh/m² (Bozdog, Ö & Seçer, M. 2007). The average mass of a reinforced concrete building is about 1000 kg/m². Therefore, energy consumption during demolition is 0,01 kWh/kg. A conservative assumption has been made that the energy consumed during demolition of a steel building is the same as that of a concrete building. The source of energy is diesel fuel used by work machines. It is assumed that 100% of the waste is collected and transported to the waste treatment centre.

- Transport (C2)

Transportation distance to treatment is assumed as 300 km and the transportation method is assumed to be lorry.

Materials	Foreign countries distance (km)	Shipping distance (km)	Domestic distance (km)
Iron scrap (domestic)			37.91
Iron scrap(import)	51.37	681.61	12.80
Pig iron	2089.84	920.62	21.40

- Waste processing (C3)

Approximately 95% of steel is assumed to be recycled based on World Steel Association, 2020.

- Disposal (C4)

It is assumed that the remaining 5 % of steel is taken to landfill for final disposal.

- Reuse-Recovery-Recycling-potential (D)

Due to the recycling process, the end-of-life product is converted into recycled steel.

Content information

Product components	Weight, %	Post-consumer material, weight-%	Renewable material, weight-%
Iron scrap	92.3%	86.0%	0%
Pig iron	1.6%	0%	0%
Others	6.1%	0%	0%
TOTAL	100.0%	0%	0%

Results of the environmental performance indicators

Mandatory impact category indicators according to EN 15804

Results per functional or declared unit							
Indicator	Unit	A1-A3	C1	C2	C3	C4	D
GWP-fossil	kg CO ₂ eq.	7.99E+02	3.57E+00	3.05E+01	5.90E+01	3.58E+00	4.69E+01
GWP-biogenic	kg CO ₂ eq.	4.36E+01	8.20E-04	1.16E-02	1.35E-02	4.32E-03	-2.03E-02
GWP-luluc	kg CO ₂ eq.	5.41E-01	4.02E-04	1.56E-02	6.64E-03	1.00E-03	1.00E-03
GWP-total	kg CO ₂ eq.	8.43E+02	3.57E+00	3.05E+01	5.90E+01	3.59E+00	4.66E+01
ODP	kg CFC 11 eq.	1.11E-05	5.68E-08	5.18E-07	9.39E-07	6.13E-08	1.06E-13
AP	mol H ⁺ eq.	5.53E+00	3.31E-02	8.35E-02	5.47E-01	3.20E-02	1.04E-01
EP-freshwater	kg P eq.	3.97E-01	1.10E-04	2.56E-03	1.81E-03	1.43E-04	8.81E-06
EP-marine	kg N eq.	9.09E-01	1.53E-02	2.20E-02	2.54E-01	1.46E-02	1.83E-02
EP-terrestrial	mol N eq.	9.36E+00	1.67E-01	2.27E-01	2.76E+00	1.58E-01	1.61E-01
POCP	kg NMVOC eq.	2.97E+00	4.94E-02	1.20E-01	8.16E-01	4.75E-02	7.43E-02
ADP-minerals&metals*	kg Sb eq.	4.84E-03	1.25E-06	8.54E-05	2.06E-05	2.03E-06	1.21E-04
ADP-fossil*	MJ	1.12E+04	4.68E+01	4.60E+02	7.73E+02	5.07E+01	4.45E+02
WDP	m ³	2.29E+02	1.01E-01	2.34E+00	1.67E+00	4.30E-01	5.81E+02
Acronyms	GWP-fossil = Global Warming Potential fossil fuels; GWP-biogenic = Global Warming Potential biogenic; GWP-luluc = Global Warming Potential land use and land use change; ODP = Depletion potential of the stratospheric ozone layer; AP = Acidification potential, Accumulated Exceedance; EP-freshwater = Eutrophication potential, fraction of nutrients reaching freshwater end compartment; EP-marine = Eutrophication potential, fraction of nutrients reaching marine end compartment; EP-terrestrial = Eutrophication potential, Accumulated Exceedance; POCP = Formation potential of tropospheric ozone; ADP-minerals&metals = Abiotic depletion potential for non-fossil resources; ADP-fossil = Abiotic depletion for fossil resources potential; WDP = Water (user) deprivation potential, deprivation-weighted water consumption						

* Disclaimer: The results of this environmental impact indicator shall be used with care as the uncertainties of these results are high or as there is limited experience with the indicator.

Additional mandatory and voluntary impact category indicators

Results per functional or declared unit							
Indicator	Unit	A1-A3	C1	C2	C3	C4	D
GWP-GHG ¹	kg CO ₂ eq.	7.99E+02	3.57E+00	3.05E+01	5.90E+01	3.59E+00	4.66E+01

¹ This indicator accounts for all greenhouse gases except biogenic carbon dioxide uptake and emissions and biogenic carbon stored in the product. As such, the indicator is identical to GWP-total except that the CF for biogenic CO₂ is set to zero.

Resource use indicators

Results per functional or declared unit							
Indicator	Unit	A1-A3	C1	C2	C3	C4	D
PERE	MJ	5.03E+02	2.13E-01	4.39E+00	3.51E+00	2.68E-01	-1.43E+00
PERM	MJ	1.64E+02	5.35E-02	1.44E+00	8.83E-01	7.81E-02	1.50E-02
PERT	MJ	6.67E+02	2.66E-01	5.82E+00	4.40E+00	3.46E-01	-1.41E+00
PENRE	MJ	1.18E+04	4.97E+01	4.89E+02	8.22E+02	5.39E+01	4.66E+02
PENRM	MJ	8.23E-01	3.90E-04	1.50E-02	6.44E-03	3.70E-03	0.00E+00
PENRT	MJ	1.18E+04	4.97E+01	4.89E+02	8.22E+02	5.39E+01	4.66E+02
SM	kg	9.59E+01	0	0	0	0	0
RSF	MJ	0	0	0	0	0	0
NRSF	MJ	0	0	0	0	0	0
FW	m ³	6.26E+00	3.67E-03	7.34E-02	6.07E-02	1.17E-02	2.03E-01
Acronyms	PERE = Use of renewable primary energy excluding renewable primary energy resources used as raw materials; PERM = Use of renewable primary energy resources used as raw materials; PERT = Total use of renewable primary energy resources; PENRE = Use of non-renewable primary energy excluding non-renewable primary energy resources used as raw materials; PENRM = Use of non-renewable primary energy resources used as raw materials; PENRT = Total use of non-renewable primary energy re-sources; SM = Use of secondary material; RSF = Use of renewable secondary fuels; NRSF = Use of non-renewable secondary fuels; FW = Use of net fresh water						

Waste indicators

Results per functional or declared unit							
Indicator	Unit	A1-A3	C1	C2	C3	C4	D
Hazardous waste disposed	kg	2.97E-02	3.15E-04	2.90E-03	5.20E-03	3.29E-04	0.00E+00
Non-hazardous waste disposed	kg	1.34E+02	6.70E-02	4.01E+01	1.11E+00	5.01E+01	0.00E+00
Radioactive waste disposed	kg	3.75E-02	5.13E-06	1.00E-04	8.47E-05	6.53E-06	0.00E+00

Output flow indicators

Results per functional or declared unit							
Indicator	Unit	A1-A3	C1	C2	C3	C4	D
Components for re-use	kg	0	0	0	0	0	0
Material for recycling	kg	0	0	0	9.50E+02	0	0

Materials for energy recovery	kg	0	0	0	0	0	0
Exported energy, electricity	MJ	0	0	0	0	0	0
Exported energy, thermal	MJ	0	0	0	0	0	0

Additional environmental information

Regulated Hazardous Substance

- The base material of the steel plate(heat treatment) is iron. No substances required to be reported as hazardous are associated with the production of this product.

Dangerous Substance

- All chemicals used in the Pohang factory are managed in accordance with the Korean Toxic Chemicals Control Act. Substances listed on the Candidate List of Substances of Very High Concern (SVHC) for authorization published by European Chemicals Agency (ECHA) are not contained in the steel in declarable quantities.

Information related to Sector EPD

This EPD® is individual.

References

General Programme Instructions of the International EPD® System. Version 4.0.

PCR 2019:14 Construction products (EN 15804:A2) (1.3.1)

EN 15804:2012+A2:2019. Sustainability of construction works – Environmental product declarations – ISO 14025:2006. Environmental labels and declarations — Type III environmental declarations — Principles and procedures

ISO 14040:2006. Environmental management – Life cycle assessment – Principles and framework

ISO 14044:2006. Environmental management – Life cycle assessment – Requirements and guidelines

LCA software SimaPro 9.5.0.1

