

# Environmental Product Declaration



In accordance with ISO 14025:2006 and EN 15804:2012+A2:2019/AC:2021 for:

## Hinges C.H.I.C.

from

**GIESSE S.p.A.**



Programme:	The International EPD® System, <a href="http://www.environdec.com">www.environdec.com</a>
Programme operator:	EPD International AB
EPD registration number:	S-P-08397
Publication date:	2023-04-07
Revision date:	2024-07-09
Valid until:	2028-04-05

*An EPD should provide current information and may be updated if conditions change. The stated validity is therefore subject to the continued registration and publication at [www.environdec.com](http://www.environdec.com)*

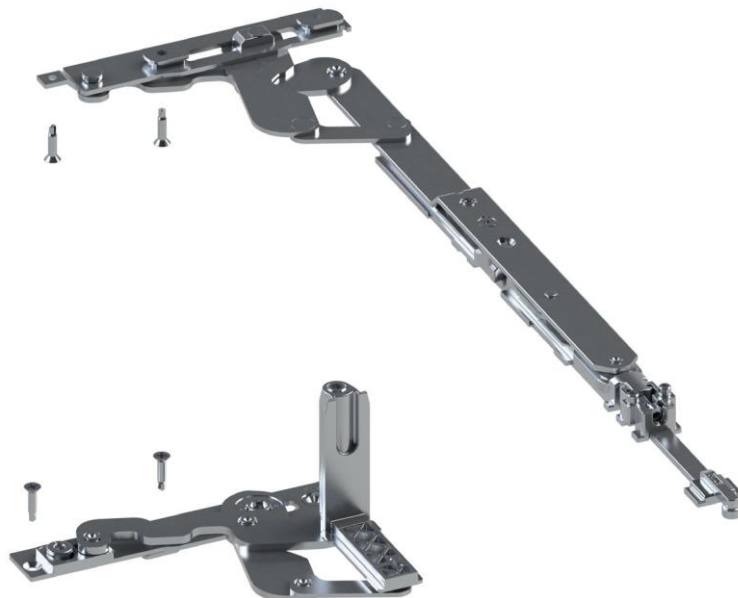

## General information

### Programme information

<b>Programme:</b>	The International EPD® System
<b>Address:</b>	EPD International AB Box 210 60 SE-100 31 Stockholm Sweden
<b>Website:</b>	<a href="http://www.environdec.com">www.environdec.com</a>
<b>E-mail:</b>	<a href="mailto:info@environdec.com">info@environdec.com</a>

<b>Accountabilities for PCR, LCA and independent, third-party verification</b>
<b>Product Category Rules (PCR)</b>
CEN standard EN 15804:2012+A2:2019 serves as the Core Product Category Rules (PCR)
Product Category Rules (PCR): Construction products, PCR 2019:14 (EN 15804:A2+A2:2019), version 1.2.5.
PCR review was conducted by: The Technical Committee of the International EPD®System. Chair: Claudia A. Peña. The review panel may be contacted via <a href="mailto:info@environdec.com">info@environdec.com</a>
<b>Life Cycle Assessment (LCA)</b>
LCA accountability: Valerio Venturi <a href="mailto:valerio.venturi@tyman.com">valerio.venturi@tyman.com</a> GIESSE S.p.A. <a href="https://www.tyman-international.com">https://www.tyman-international.com</a> ; Federica Gilardelli <a href="mailto:f.gilardelli@greenwichsrl.it">f.gilardelli@greenwichsrl.it</a> Greenwich S.r.l. <a href="https://greenwichsrl.it">https://greenwichsrl.it</a>
<b>Third-party verification</b>
Independent third-party verification of the declaration and data, according to ISO 14025:2006, via:  <input checked="" type="checkbox"/> EPD verification by accredited certification body  Third-party verification: DNV Business Assurance Italy S.r.l. is an approved certification body accountable for the third-party verification  The certification body is accredited by: Accredia  Procedure for follow-up of data during EPD validity involves third-party verifier: <input type="checkbox"/> yes <input checked="" type="checkbox"/> no

The EPD owner has the sole ownership, liability, and responsibility for the EPD.

EPDs within the same product category but registered in different EPD programmes, or not compliant with EN 15804:2012+A2:2019, may not be comparable. For two EPDs to be comparable, they must be based on the same PCR (including the same version number) or be based on fully-aligned PCRs or versions of PCRs; cover products with identical functions, technical performances and use (e.g. identical declared/functional units); have equivalent system boundaries and descriptions of data; apply equivalent data quality requirements, methods of data collection, and allocation methods; apply identical cut-off rules and impact assessment methods (including the same version of characterisation factors); have equivalent content declarations; and be valid at the time of comparison. For further information about comparability, see EN 15804:2012+A2:2019 and ISO 14025:2006.

## Company information

Owner of the EPD: GIESSE S.p.A.

Contact: Valerio Venturi [valerio.venturi@schlegelgiesse.com](mailto:valerio.venturi@schlegelgiesse.com) and Giovanni Liconti [giovanni.liconti@schlegelgiesse.com](mailto:giovanni.liconti@schlegelgiesse.com)

Description of the organisation: Giesse is the brand that opens up new hardware solution frontiers for aluminium windows and doors. Technical innovation and extremely high quality are at the core of our daily work. Our focus is on achieving complete customer satisfaction, from design and production to providing our clients with a trusted partner, every step of the way.

GIESSE S.p.A. was founded in 1965 and in 2016 it was acquired by Schlegel, a leading English company in the sealing systems sector. Both companies are part of the international division of Tyman PLC, a group listed on the London stock exchange, with a commercial network capable of reaching customers in over 100 countries and offering them the highest degree of satisfaction, a wide range of standard components and boasts over 150 registered patents.

Product-related or management system-related certifications: ISO 9001:2015 and ISO 14001:2015 certificates, Cradle to Cradle Certified<sup>®</sup> Silver, Product certification RAL-GZ 607/3.



Name and location of production site: GIESSE S.p.A. Via Tubertini 1, 40054 Budrio (Bologna BO), Italy.

## Product information

Product name: hinge CHIC

Product identification: CHIC – HINGE LEAF KIT 043541/2 CHIC – T/T KIT ARM T1 043551/2, CHIC – T/T KIT ARM T2 043561/2, CHIC – T/T KIT ARM T1 (NO MICRO) 043591/2, CHIC 150 – HINGE LEAF KIT 043641/2, CHIC 150 – T/T KIT ARM T1 043651/2, CHIC 150 – T/T KIT ARM T2 043661/2, CHIC 130 – HINGE LEAF KIT 044241/2, CHIC 130 – T/T KIT ARM T1 044251/2, CHIC 130 – T/T KIT ARM T2 044261/2

Product description:

CHIC - HINGE LEAF KIT 043541/2

CHIC 150 - HINGE LEAF KIT 043641/2

CHIC 130 - HINGE LEAF KIT 044241/2

Set of hinges (top and bottom) for side-hung or secondary sash with tilt-and-turn.

Sash opening to 180°.

Maximum load capacity up to 150 kg.

Available in right- and left-hand versions.

Assembly is simple, fast and easy using the special pre-assembled cams.

When there is an additional fastening mechanism, you need to use the CHIC fastening element.

Both hinges are adjustable (3D).

CHIC - T/T KIT ARM T1 043551/2

CHIC - T/T KIT ARM T2 043561/2

CHIC - T/T KIT ARM T1 (NO MICRO) 043591/2

CHIC 150 - T/T KIT ARM T1 043651/2

CHIC 150 - T/T KIT ARM T2 043661/2

CHIC 130 - T/T KIT ARM T1 044251/2

CHIC 130 - T/T KIT ARM T2 044261/2

Set of hinges (top and bottom), completely pre-assembled and ready to be installed on the profile.

They enable tilt-and-turn opening combined with the mechanisms.

Available in right- and left-hand versions.

Micro-ventilation and logica versions.

The arm is equipped with micro-ventilation as standard (adjustable).

Moving the fastening pawl takes the arm from conventional to logica.

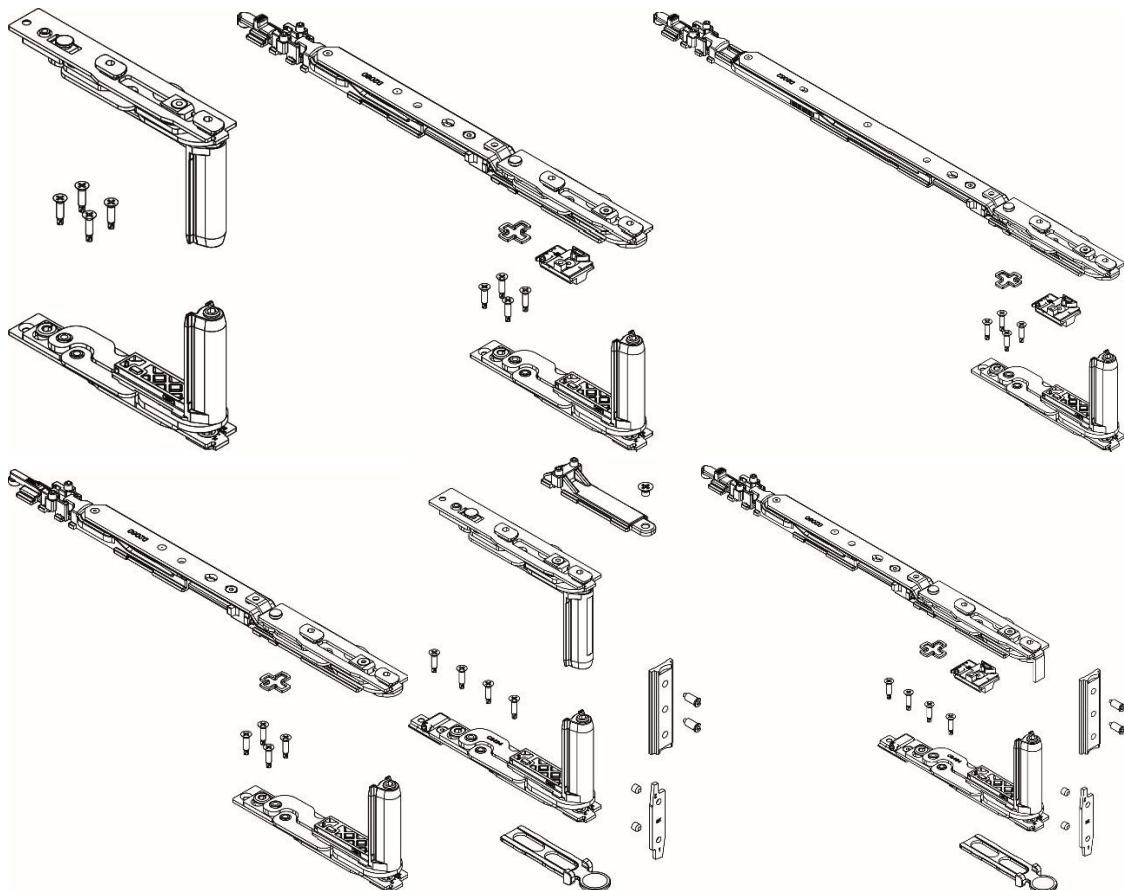

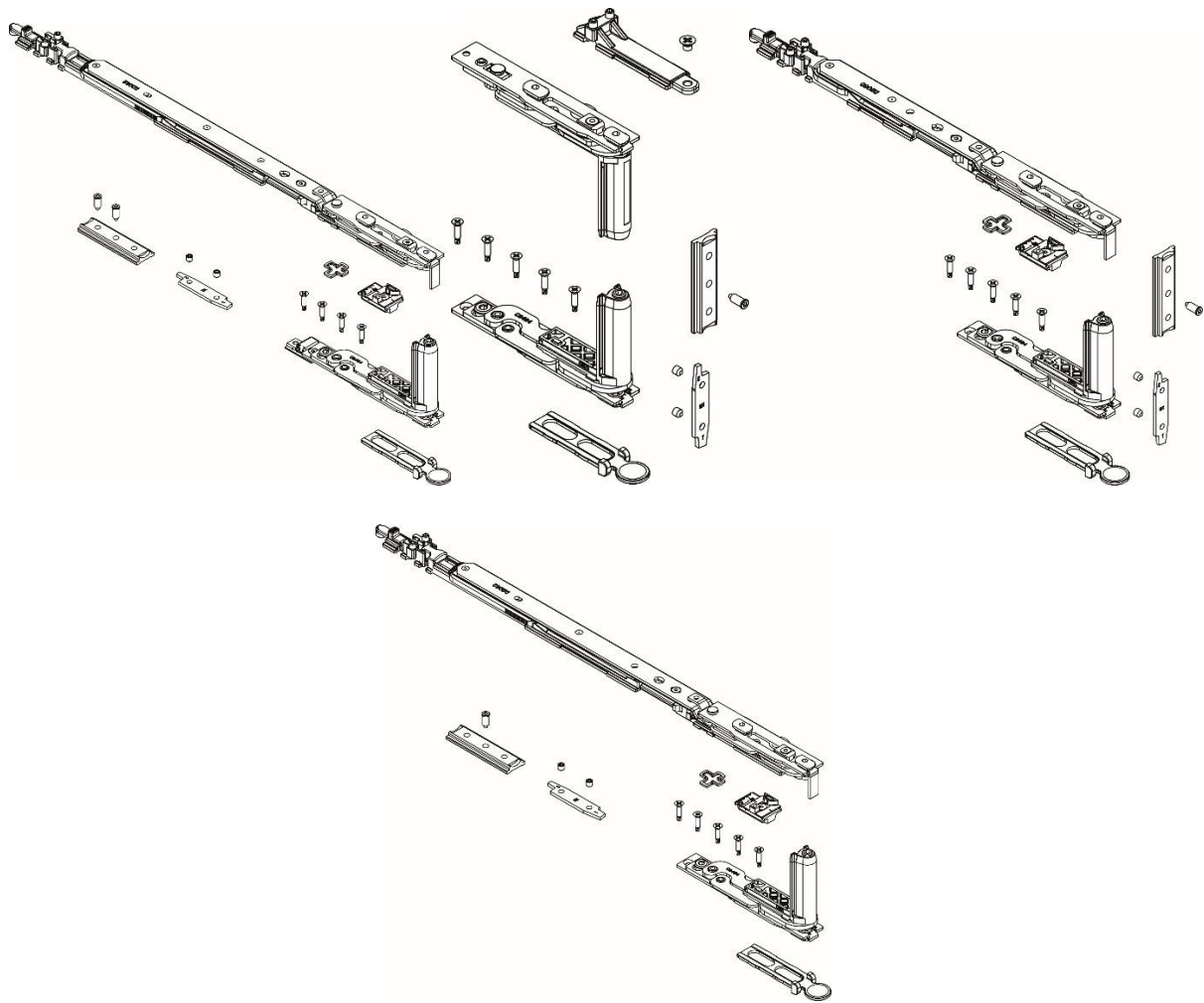

UN CPC code: 4212

Geographical scope: Europe

### **LCA information**

Functional unit / declared unit: 1 kg of hinge

Time representativeness: 2022

Database(s) and LCA software used: SimaPro 9.5.0.2 and Ecoinvent 3.9.1

Description of system boundaries: Cradle to gate with modules C1–C4 and module D (A1–A3 + C + D).

The current EPD certificate follows the indications reported in the third option of paragraph 4.6.1 of the reference PCR (2019:14 Construction products), which considers the results of the “worst-case product”. The General Programme Instructions (GPI) of the International EPD System version 4.0 are also contemplated.

System diagram:

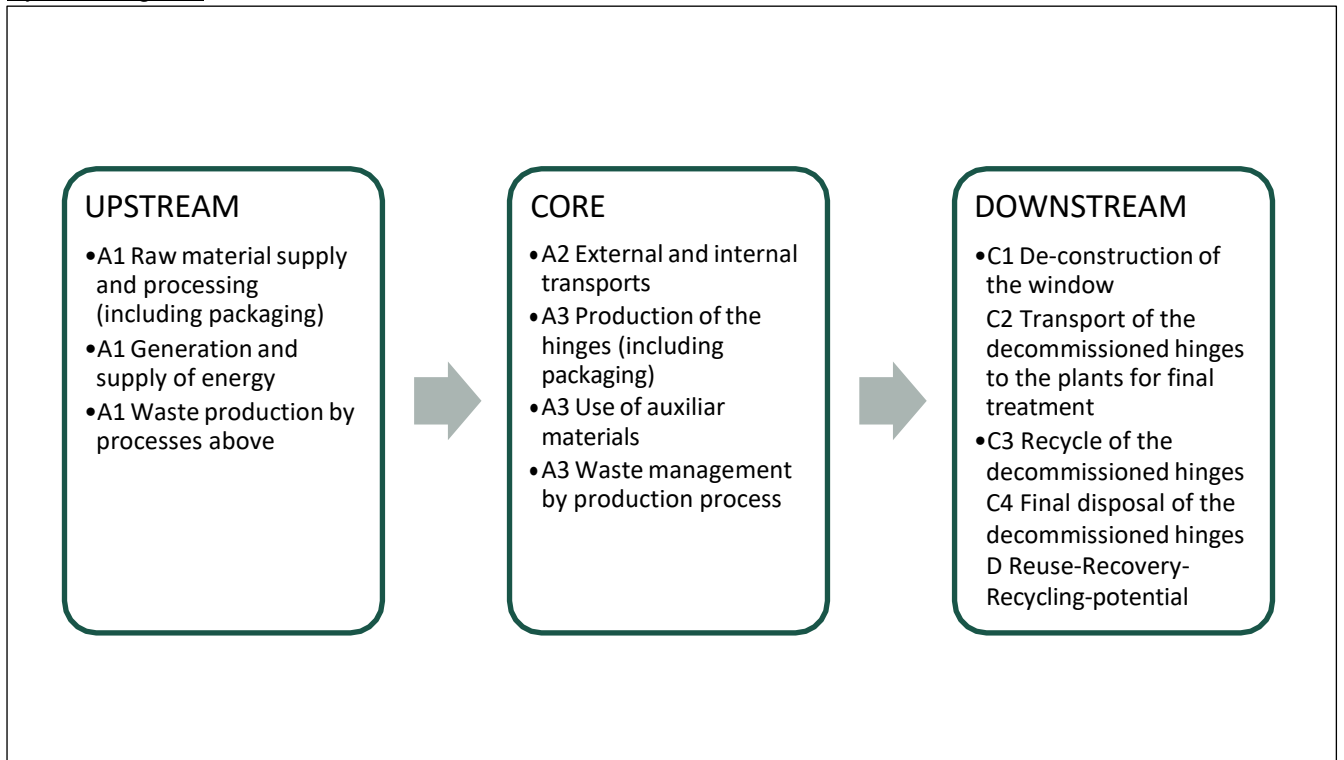

More information:

Valerio Venturi [valerio.venturi@tyman.com](mailto:valerio.venturi@tyman.com); Federica Gilardelli [f.gilardelli@greenwichsrl.it](mailto:f.gilardelli@greenwichsrl.it)

Modules declared, geographical scope, share of specific data (in GWP-GHG results) and data variation (in GWP-GHG results):

	Product stage			Construction process stage		Use stage							End of life stage				Resource recovery stage
	Raw material supply	Transport	Manufacturing	Transport	Construction installation	Use	Maintenance	Repair	Replacement	Refurbishment	Operational energy use	Operational water use	De-construction demolition	Transport	Waste processing	Disposal	Reuse-Recovery-Recycling-potential
Module	A1	A2	A3	A4	A5	B1	B2	B3	B4	B5	B6	B7	C1	C2	C3	C4	D
Modules declared	X	X	X	ND	ND	ND	ND	ND	ND	ND	ND	ND	X	X	X	X	X
Geography	EU27	EU27	ITA	ND	ND	ND	ND	ND	ND	ND	ND	ND	EU27	EU27	EU27	EU27	EU27
Specific data used	>90%			ND	ND	ND	ND	ND	ND	ND	ND	ND	-	-	-	-	-
Variation – products	14,74%			ND	ND	ND	ND	ND	ND	ND	ND	ND	-	-	-	-	-
Variation – sites	-			ND	ND	ND	ND	ND	ND	ND	ND	ND	-	-	-	-	-

## Content information

The data relating to the weight of the hinges refer to the net quantities.

Product components	Weight [g]										Post-consumer material, weight-% [worst case]	Biogenic material, weight-% and kg C/kg [worst case]
	043541/2 CHIC - HINGE LEAF KIT	043551/2 CHIC - T/T KIT ARM T1	043561/2 CHIC - T/T KIT ARM T2	043591/2 CHIC - T/T KIT BR. T1 NO MICRO)	043641/2 CHIC 150 - HINGE LEAF KIT	043651/2 CHIC 150 - T/T KIT ARM T1	043661/2 CHIC 150 - T/T KIT ARM T2	044241/2 CHIC 130 - KIT CERNIERE ANTA	044251/2 CHIC 130 - T/T KIT ARM T1	044261/2 CHIC 130 - T/T KIT ARM T2		
Aluminium	0.0	11.2	18.0	11.1	13.1	24.5	31.4	13.3	24.6	31.4	0,0	0,0
Stainless steel	91.3	200.2	253.4	198.4	113.0	211.9	265.1	110.1	209.0	262.2	0,0	0,0
Steel	296.8	270.0	270.0	270.0	291.2	268.3	268.3	291.2	268.3	268.3	0,0	0,0
Polyamide	0.0	0.9	1.3	0.9	4.0	4.9	5.3	4.0	4.9	5.3	0,0	0,0
Polyoxymethylene	4.1	2.2	2.2	2.2	4.1	2.2	2.2	4.1	2.2	2.2	0,0	0,0
Other metal alloys	10.6	10.2	10.2	10.2	13.4	14.8	14.8	13.4	14.8	14.8	0,0	0,0
Zinc alloy	149.2	219.4	284.4	201.7	205.2	229.0	293.9	195.6	219.4	284.4	0,0	0,0
<b>Total weight (g)</b>	552.0	714.1	839.5	694.5	644.0	755.6	881.0	631.7	743.2	868.6		
Packaging materials	Weight [g]										Weight-% (versus the product) [worst case]	Weight biogenic carbon, kg C/kg [worst case]
	Wood	Cardboard	Plastic	TOTAL (g)	Wood	Cardboard	Plastic	TOTAL (g)	Wood	Cardboard		
Wood	16.7	16.7	25,0	16.7	16.7	16.7	25,0	16.7	16.7	25,0	2,9	0,03
Cardboard	54.9	23.1	31,8	23.1	61.4	23.1	31,8	55.1	23.1	31,8	3,7	0,04
Plastic	1.3	10.0	10,1	10,0	4,7	13,0	13,1	5,0	13,0	13,1	1,5	0,01
<b>TOTAL (g)</b>	72.9	49.8	66.9	49.8	82.8	52.8	69.9	76.8	52.8	69,99		



## Environmental Information

### CHIC

#### Potential environmental impact – mandatory indicators according to EN 15804

The following tables show the maximum values of the environmental indicators for each module chosen among those of the products studied in this document.

Results per functional or declared unit							
Indicator	Unit	A1-A3	C1	C2	C3	C4	D
GWP-total	kg CO <sub>2</sub> eq.	6.45E+00	0.00E+00	1.38E-01	1.31E-02	8.93E-04	-1.86E+00
GWP-fossil	kg CO <sub>2</sub> eq.	6.36E+00	0.00E+00	1.38E-01	1.31E-02	8.92E-04	-1.86E+00
GWP-biogenic	kg CO <sub>2</sub> eq.	7.08E-02	0.00E+00	1.38E-05	4.30E-06	2.60E-07	-1.22E-03
GWP-luluc	kg CO <sub>2</sub> eq.	2.11E-02	0.00E+00	1.75E-05	3.13E-06	3.90E-07	-8.26E-04
ODP	kg CFC 11 eq.	1.18E-07	0.00E+00	2.17E-09	8.74E-10	1.81E-11	-3.56E-08
AP	mol H <sup>+</sup> eq.	8.91E-02	0.00E+00	7.57E-04	1.73E-05	4.77E-06	-7.86E-03
EP-freshwater	kg P eq.	4.63E-03	0.00E+00	2.58E-06	3.62E-06	5.50E-08	-8.96E-04
EP-marine	kg N eq.	8.39E-03	0.00E+00	3.29E-04	4.20E-06	7.94E-06	-1.74E-03
EP-terrestrial	mol N eq.	8.67E-02	0.00E+00	3.56E-03	4.03E-05	1.95E-05	-1.86E-02
POCP	kg NMVOC eq.	3.19E-02	0.00E+00	1.39E-03	1.54E-05	6.86E-06	-8.83E-03
ADP-fossil*	MJ	8.42E+01	0.00E+00	1.80E+00	6.17E-02	1.57E-02	-1.95E+01
ADP-minerals&metals*	kg Sb eq.	7.81E-04	0.00E+00	8.89E-08	1.63E-08	9.09E-10	-1.59E-05
WDP*	m <sup>3</sup>	2.86E+00	0.00E+00	3.39E-03	1.63E-03	6.90E-04	-3.46E-01
Acronyms	GWP-fossil = Global Warming Potential fossil fuels; GWP-biogenic = Global Warming Potential biogenic; GWP-luluc = Global Warming Potential land use and land use change; ODP = Depletion potential of the stratospheric ozone layer; AP = Acidification potential, Accumulated Exceedance; EP-freshwater = Eutrophication potential, fraction of nutrients reaching freshwater end compartment; EP-marine = Eutrophication potential, fraction of nutrients reaching marine end compartment; EP-terrestrial = Eutrophication potential, Accumulated Exceedance; POCP = Formation potential of tropospheric ozone; ADP-minerals&metals = Abiotic depletion potential for non-fossil resources; ADP-fossil = Abiotic depletion for fossil resources potential; WDP = Water (user) deprivation potential, deprivation-weighted water consumption						

\* Disclaimer: The results of this environmental impact indicator shall be used with care as the uncertainties of these results are high or as there is limited experience with the indicator.

## Potential environmental impact – additional mandatory and voluntary indicators

Indicator	Unit	A1-A3	C1	C2	C3	C4	D
GWP-GHG	kg CO <sub>2</sub> eq.	6.41E+00	0.00E+00	1.38E-01	1.31E-02	8.74E-04	-1.85E+00

### Results per functional or declared unit

Indicator	Unit	A1-A3	C1	C2	C3	C4	D
PM	disease inc.	4.29E-07	0.00E+00	1.81E-08	1.86E-10	1.04E-10	-1.41E-07
IRP	kBq U235 eq.	8.73E-01	0.00E+00	5.94E-04	2.30E-04	1.06E-05	-6.79E-02
ETP-fw	CTUe	1.82E+02	0.00E+00	8.76E-01	2.02E-01	8.42E-03	-6.65E+00
HTP-nc	CTUh	2.80E-08	0.00E+00	2.04E-11	7.89E-12	2.76E-13	-1.17E-08
HTP-c	CTUh	4.33E-07	0.00E+00	3.53E-10	6.09E-11	3.99E-12	-2.05E-08
SQP	Pt	3.97E+01	0.00E+00	2.00E-01	1.00E-02	3.13E-02	-6.15E+00

*Additional voluntary indicators e.g. the voluntary indicators from EN 15804 or the global indicators according to ISO 21930:2017*

## Use of resources

### Results per functional or declared unit

Indicator	Unit	A1-A3	C1	C2	C3	C4	D
PERE	MJ	2.14E+01	0.00E+00	7.10E-03	2.70E-03	1.42E-04	-1.97E+00
PERM	MJ	2.51E+00	0.00E+00	0.00E+00	0.00E+00	0.00E+00	0.00E+00
PERT	MJ	2.39E+01	0.00E+00	7.10E-03	2.70E-03	1.42E-04	-1.97E+00
PENRE	MJ	8.42E+01	0.00E+00	1.80E+00	6.17E-02	1.57E-02	-1.95E+01
PENRM	MJ	1.28E+00	0.00E+00	0.00E+00	0.00E+00	0.00E+00	0.00E+00
PENRT	MJ	8.53E+01	0.00E+00	1.80E+00	6.17E-02	1.57E-02	-1.95E+01
SM	kg	0.00E+00	0.00E+00	0.00E+00	0.00E+00	0.00E+00	0.00E+00

RSF	MJ	0.00E+00	0.00E+00	0.00E+00	0.00E+00	0.00E+00	0.00E+00
NRSF	MJ	0.00E+00	0.00E+00	0.00E+00	0.00E+00	0.00E+00	0.00E+00
FW	m <sup>3</sup>	1.03E-01	0.00E+00	1.22E-04	4.32E-05	1.66E-05	-1.09E-02
Acronyms	PERE = Use of renewable primary energy excluding renewable primary energy resources used as raw materials; PERM = Use of renewable primary energy resources used as raw materials; PERT = Total use of renewable primary energy resources; PENRE = Use of non-renewable primary energy excluding non-renewable primary energy resources used as raw materials; PENRM = Use of non-renewable primary energy resources used as raw materials; PENRT = Total use of non-renewable primary energy re-sources; SM = Use of secondary material; RSF = Use of renewable secondary fuels; NRSF = Use of non-renewable secondary fuels; FW = Use of net fresh water						

## Waste production and output flows

### Waste production

Results per functional or declared unit							
Indicator	Unit	A1-A3	C1	C2	C3	C4	D
Hazardous waste disposed	kg	3.25E-03	0.00E+00	1.21E-05	4.13E-07	8.27E-08	-1.64E-04
Non-hazardous waste disposed	kg	1.57E+00	0.00E+00	9.08E-03	2.36E-03	1.01E-01	-7.98E-01
Radioactive waste disposed	kg	2.26E-04	0.00E+00	1.31E-07	5.95E-08	2.49E-09	-1.71E-05

### Output flows

Results per functional or declared unit							
Indicator	Unit	A1-A3	C1	C2	C3	C4	D
Components for re-use	kg	0.00E+00	0.00E+00	0.00E+00	0.00E+00	0.00E+00	0.00E+00
Material for recycling	kg	3.30E-02	0.00E+00	0.00E+00	8.98E-01	0.00E+00	0.00E+00
Materials for energy recovery	kg	0.00E+00	0.00E+00	0.00E+00	5.32E-03	0.00E+00	0.00E+00
Exported energy, electricity	MJ	0.00E+00	0.00E+00	0.00E+00	0.00E+00	0.00E+00	0.00E+00
Exported energy, thermal	MJ	0.00E+00	0.00E+00	0.00E+00	0.00E+00	0.00E+00	0.00E+00

## Additional environmental information

CHIC corrosion resistance grade 4 (240 h according to EN 13126-8:2017)

## Differences versus previous versions

Change of the year of data collected from 2021 to 2022.

Update of all indicator tables based on new Database and LCA software used: Ecoinvent 3.9.1 and SimaPro 9.5.0.2

## References

General Programme Instructions of the International EPD® System. Version 4.0.

UNI EN ISO 14040: 2021, Gestione ambientale – Valutazione del ciclo di vita – Principi e quadro di riferimento.

UNI EN ISO 14044: 2021, Gestione ambientale – Valutazione del ciclo di vita – Requisiti e linee guida.

UNI EN ISO 14025:2010, Etichette e dichiarazioni ambientali - Dichiarazioni ambientali di Tipo III - Principi e procedure

UNI EN 15804:2012 + A2:2019, Sostenibilità delle costruzioni – Dichiarazioni ambientali di prodotto – Regole chiave di sviluppo per categoria di prodotto.

PCR 2019 :14 Construction products (EN 15804:2012+A2 :2019) (1.2.5)

EuRIC AISBL – Recycling: Bridging Circular Economy & Climate Policy 80 Boulevard Auguste Reyers, B-1030 Brussels +32 2 706 87 24. [www.euric-aisbl.eu](http://www.euric-aisbl.eu)

Plastics - the Facts 2021 An analysis of European plastics production, demand and waste data Background report. Analisi del ciclo di vita delle cerniere CHIC e FULCRA GIESSE. Aprile 2024.

Redatto da V. Venturi GIESSE S.p.A. , F. Gilardelli Greenwich S.r.l.



[www.environdec.com](http://www.environdec.com)