



FORZA
DOORS & FRAMES



FRAME & IRONMONGERY INSTALLATION GUIDE ON REVERSE

	CERTIFICATED FIRE DOOR DO NOT REMOVE THIS LABEL	IFC Certification FRTD497	IFC Certification Ltd T: +44 (0)1844 275500 www.ifccertification.com FD 90 BS 476:PART 22	FORZA FIRE DOOR NO:	IFC Certification Ltd T: +44 (0)1844 275500 www.ifccertification.com FD 90s BS 476:PART 22	FORZA FIRE DOOR NO:
			IFC Certification Ltd T: +44 (0)1844 275500 www.ifccertification.com FD 120 BS 476:PART 22	FORZA FIRE DOOR NO:	IFC Certification Ltd T: +44 (0)1844 275500 www.ifccertification.com FD 120s BS 476:PART 22	FORZA FIRE DOOR NO:

FIRE RESISTANT TIMBER FIRE DOORS & FRAMES

TO BS 476: PART 22 : 1987 - PRODUCT CERTIFICATE NO. FRTD497

This product certificate certifies that FORZA DOORS LTD Manufacture in the UK the following fire doors and door assemblies

FORZA FD90(S) FD120(S)

and have satisfied the requirements of The IFC CERTIFICATION LTD scheme that includes the testing of products to BS476: Part 22, the inspection of Factory Production Control and continuing surveillance audits and testing of samples of products taken from production.

The product specification and field of application to achieve 90 and 120 minutes integrity are detailed in:



SCHEDULE REF: PAR/10918/01 FD90
SCHEDULE REF: PAR/10922/01 FD120
PROJECT REF:

Forza Doors Ltd
Forza House
24A/24C Star Road Trading Estate
Partridge Green, Horsham
West Sussex RH13 8RA



CONTRACTORS INSTALLATION STATEMENT

The FORZA FIRE DOOR No:

has been installed in accordance with the Forza Installation Guide (see reverse) by the trained installation team of:

Company: _____

To the Project of works Ref No: _____

At: _____

Signed: _____

Date: _____

(On behalf of the Contractor)

Follow Za the Installa's instruction guide supplied. Lets get it right!



FIRE CERTIFICATE - PLACE IN BUILDING FIRE SAFETY MANUAL

(BS9999:2017 - Section9, Annex H)

CORRECT INSTALLATION CHECKLIST - MUST BE OBSERVED!

- ✓ 1. Frame to wall gaps /packing /gap sealant
- ✓ 2. Hinges/Pivots position & no missing screws
- ✓ 3. Door to Frame & Threshold gaps
- ✓ 4. Fire seals (intumescent) in position
- ✓ 5. Smoke seals (if required) allow door to shut and fill all gaps
- ✓ 6. Lockset engages/releases
- ✓ 7. Closer suitably adjusted to close door
- ✓ 8. "Firedoor Keep Shut" sign visible on door or frame

**FIRE DOOR LABEL
AFFIX TO DOOR OR
FRAME ON INSTALL**

Follow us on: /forzadoorsltd /forzadoorsltd

Find us on: /forzadoorsltd /forzadoorsltd

**TICK HERE ON
COMPLETION**

FD90/120/IFC-CERT/v4/M/arcn2024

FORZA FD90/FD120 - FRAME & DOOR INSTALLATION GUIDE

SUPPORTING CONSTRUCTION

The supporting construction may be Timber or Steel stud plasterboard partition, blockwork, brickwork or concrete walls, but shall be of a type that has been tested or assessed to provide in excess of 90/120 minutes fire resistance, at the required size, when incorporating FD90/FD120 door assembly openings. The method of forming the door assembly aperture must be as tested by the partition supplier/manufacturer.

Timber Frame Installation & Gap Tolerance

The frames must be fixed back to the supporting construction using a minimum of 5 No. steel screws in each jamb (1 No. fixing 200mm below the head, 1 No. fixing 200mm above the threshold and 3 No. fixings equally spaced in between). In the frame head 2 No. fixings are required set 200mm from the jambs for single doors and 500mm from the jambs for double doors.

Screws shall be of sufficient length to penetrate the supporting construction by at least 40mm, and shall be positioned such that they are not exploited by charring of the frame, irrespective of the direction of fire exposure. Suitably thick packers depending on frame to supporting construction gap shall be used at all fixing positions.

The gap between the frame and the supporting construction shall be between 5mm and 10mm (max) (enabling mastic and mineral wool to be positioned as per DRW6). Mineral wool to be tightly packed in the gap and capped at the perimeters of the frame with intumescent mastic to a minimum depth of 20mm.

Where the face of the frame, and the door, are flush with the face of the wall, loose architraves are optional, and have no fire performance requirements, and so can be freely specified, subject to adequate fire stopping (DRW6) FCH90 only.

For gap sealing applications, the intumescent mastic should be an approved linear gap joint sealant rated to FD90/FD120, tested and approved between the required substrates to BS EN 1366-4 or BS476: part 20.

No part of the rear of the frame section shall be exposed once installed, and door leaves must not protrude beyond the exposed face of the doorframe.

Optional: Architrave minimum 15mm overlap to frame and wall Architrave min size 45mm x 18mm FCW, but also can be optional with the correct fire stopping.

Liner size minimum 44mm x 90mm

Packer shim to match gap depth positioned at each fixing point. Remaining void tightly packed with mineral wool

Stop min 18mm thick and pinned to frame

2.5mm gap for Batwing Acoustic/ smoke seal

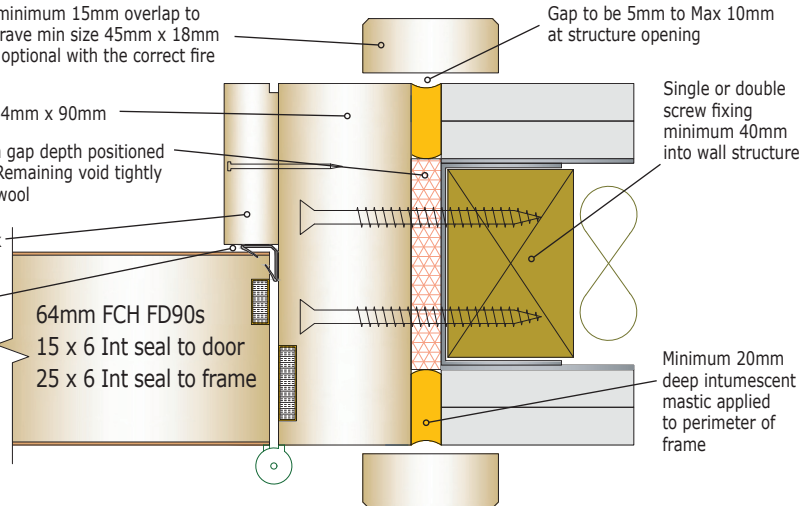

DRW6

For standard FD90/FD120 installations there shall be no feature rebates or shadow gaps at the junction of the frame and wall (such features could be assessed on an individual project basis).

The standard door assembly design should be such that single acting leaves are fully flush within the timber frame when closed. The face of leaves in double door assemblies should be flush with each other at meeting stiles when closed.

Overpanels shall be secured into the timber frame and transom using steel screws fixed through the rear of the frame members, passing at least 40mm into the center of the overpanel thickness. (Screws must not be fixed through the overpanel into the stops, or vice versa). Screws must be no more than 100mm from each corner of the overpanel, and at maximum 400mm centers, with a minimum of 2no. Screws per overpanel edge. The gap between overpanel and frame and transom should not exceed 3mm. The gap between the door and the timber frame and double door meeting stiles should be 1.5-4mm. Gaps under the door(s) should not exceed 6mm for fire performance, although, if smoke control is also required, these gaps should only be 3mm and smoke

seals should be included in accordance with BS8214:2016 .12.3

Metal Door Frames FD90 (FCH90 leaves only)

When steel frames to the specification and minimum dimensions detailed below are installed into suitable supporting constructions then the method of forming the door assembly aperture must be as tested by the frame or partition supplier/ manufacturer. The frame to be back filled with mortar or concrete only. The gap for fire performance and smoke control between the door and metal frame, double door meeting stiles and under the door to floor shall be as tested by the frame or partition supplier/manufacturer.

There shall be no feature rebates or shadow gaps at the junction of the frame and wall with steel frame unless tested by the frame or partition supplier/ manufacturer.

Flush Timber Frame Specification FD90 & FD120				
Door Type	Material Minimum Density @ 12% moisture content	Minimum Frame Face Width Single Acting	Minimum Frame Depth	Minimum Stop Width
FCH90 & FCH120	Hardwood 640kg/m ³	44mm Excl.Stop	90mm	18mm
FCW90 & FCW120	Hardwood 640kg/m ³			12mm

Metal Frame Specification & Minimum Dimensions (FCH Only)					
Material	Grade	Minimum Frame Face Width		Minimum Frame Depth	Minimum Stop Width
		Single Acting	Head/Jamb Joint		
FCH90 1.5mm thick rolled mild or stainless steel	304 or 316	40mm Excl.Stop	Mitred with welded joints or bolted tabs	100mm	13mm

Composite Frame specification FD90 & FD120				
Door Type	Material	Minimum Frame Face Width Single Acting	Minimum Frame Depth	Minimum Stop Width
FCW90 & FCW120		47mm	94mm	12mm

The Overall frame depth may be increased either in solid form or with the use of extension linings where the joint/biscuit between the main frame and extension does not intrude into the plane of the door thickness.

SMOKE AND INTUMESCENT SEALS

Ambient Temperature Smoke Seals

Separate smoke seals or combined intumescent / smoke seals that have been tested in accordance with BS EN 1634-3:2004 (ambient temperature) or BS476: part 31 : section 31,1 :1983 and demonstrated not to leak by more than 3m³/m/hr (head and jambs only) at 25Pa, may be used in conjunction with Forza door assemblies to provide smoke control. To achieve the required level of smoke control the orientation of the seals and degree of hardware interruption, door edge gaps and leaf configuration must be as tested.

Test evidence to BS 476: part 22:1987 shall demonstrate that the smoke seals will not adversely affect the overall fire resistance of FD90 & FD120 timber or mineral core door assemblies when fitted in the proposed arrangements.

The threshold gap should where practicable be sealed by a flexible edge or automatic drop seal with a leakage rate as tested above or where this is not practicable due to the interference with the closing action of the door, the threshold gap should not exceed 3mm at any point.

Intumescent Seal specification

Factory prepared machined grooves to both leaf edge and frame will accommodate the required intumescent for either FD90 & FD120 door assemblies.

Reference can be made to Forza Doors drawings on forza-doors.com:

FD90: FZD0474 / FZD0476 / FZD0479 / FZD0479

FD120: FZD0477 / FZD0480

DOOR FRAME - JOINT OPTIONS FD90 & FD120

MORTICE & TENON OPEN JOINT

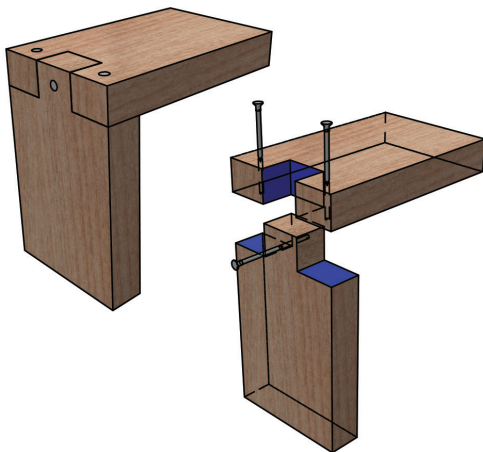

FLAT HALF-LAP JOINT

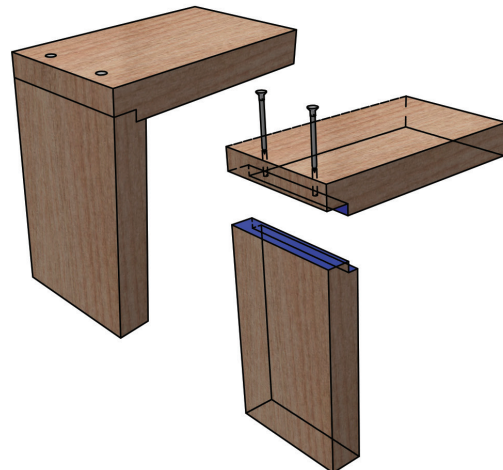

MITRED JOINT

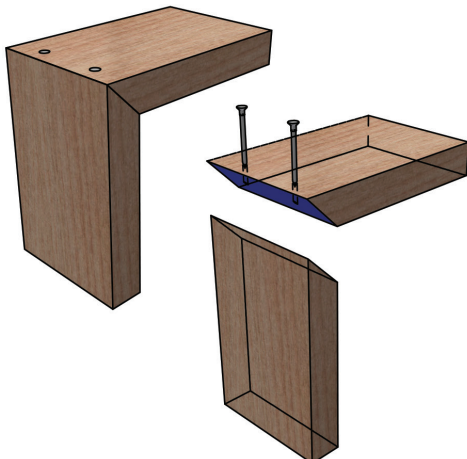

BUTT JOINT

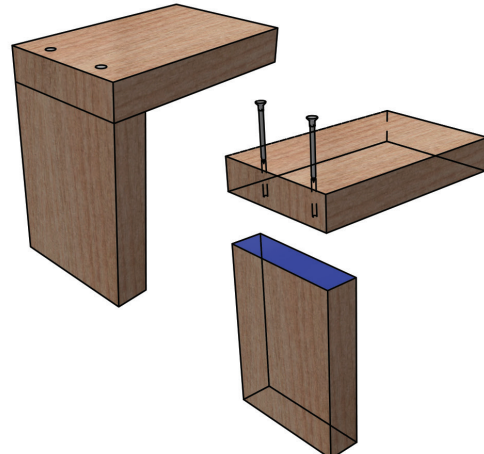

FORZA FD90/FD120 - IRONMONGERY SUITABILITY & INSTALLATION GUIDE

Knuckle Hinges: A variety of hinges have been successfully tested with the door leaves assessed. Hinges may be used, subject to compliance with the specifications below.

Hinge types: Fixed pin, washered butt, ball bearing butt, lift-off type and journal supported hinges may be used.

Number of hinges: 3no.(1&½ pair) per leaf on leaves upto 2200mm high. 4no.(2 pairs) per leaf on leaves upto 2800mm high. 5no. (2&½pair) per leaf on leaves over 2800mm high (FCW only).

Positions: FCH core: The top first hinge must be positioned 175mm down from the head of the leaf to the top of the hinge. The top second hinge to be positioned 200mm down from the bottom of the first hinge to the top of the second hinge. The bottom hinge positioned 200-250mm up from the foot of the leaf to the bottom of the hinge. All other hinges to be equally spaced between the top and bottom hinges.

FCW core: The top first hinge must be positioned 200mm down from the head of the leaf to the top of the hinge. The top second hinge to be positioned 400-500mm down from the bottom of the first hinge to the top of the second hinge. The bottom hinge positioned 200mm up from the foot of the leaf to the bottom of the hinge. All other hinges to be equally spaced between the top and bottom hinges.

Fixings: Steel screws, as recommended by the hinge manufacturer, but in no case smaller than 4mm diameter having thread for the full length, 50mm long for fixing into the door leaf and 32mm long for fixing into the frame.

Hinge blade size: 2.5-3.5mm thick x 89-110 high x 30-32mm width. These dimensions refer to the blade size, ie the part of the hinge that is recessed into the edge of the leaf/frame.

Hinge materials: Steel or Stainless Steel (Aluminium, Nylon or "maza" are not permitted). No combustible or thermally softening materials to be included.

Additional protection: All hinge blades must be bedded on minimum 2mm thick non-pressure forming intumescent material. Rising butt, non-cranked butts and spring hinges are not suitable for use on doors approved within the scope of this generic assessment. (Such hinges may be suitable on the basis of an individual and project specific fire engineering evaluation. Contact Forza Technical)

Mortice Latches /Locks

Where mortice latches or locks are fitted, they should be centred at 1000mm (+/-200mm) above the bottom of the door leaf, and should comply with the following specifications;

Latch/lock type: Mortice latches, tubular mortice latches, sashlocks, deadlocks.

Maximum dimensions: (FCH90/120 core)

- Forend plate: FDH90 FCH120 - 152mm long x 25mm wide x 3mm thick.
- Latch body: FCH90 - 18 mm thick x 165 mm high x 100mm wide.
FCH120 - 15mm thick x 108mm high x 74mm wide.
- Strike plate: FCH90 - 180mm long x 30mm wide.
FCH120 - 180mm long x 30mm wide x 1.4mm thick

(FCW90/120 core)

- Forend plate: 235mm long x 22mm x 3mm thick.
- Latch body: 165mm long x 85mm wide x 18mm thick.
- Strike plate: 180mm long x 24mm wide x 3mm thick

Additional protection

Materials: The latch body, forend, strike plate and latch keep must be encased and bedded on minimum 2mm thick non-pressure forming intumescent material.

Latches must have no essential part of their structure made from polymeric or other low melting point (<800c) materials, and should not contain any flammable materials. Over-morticing is to be avoided; mortices should be as tight as possible to the latch. If gaps around the case exceed 2mm, then these must be made good with intumescent mastic or sheet material. Holes for spindles or cylinders should be kept as small as is compatible with the operation of the hardware.

Where glazing apertures are also incorporated, and are positioned such that locks/latches are included in the margin between the aperture and door edge, care must be taken to ensure that the effective door 'stile' is not weakened by the mortice. It is a condition of this certification that, except where tubular latches are employed, the margin must be at least 75mm wider than the lock/latch mortice. If the mortice latch/lock is fitted in line with a 'rail' between two apertures, no part of the lock mortice shall be closer than 50mm to the edge of any aperture.

Door Closers: Where required by regulatory guidance or specific fire strategy each hinged door leaf must be fitted with a self-closing device unless it is normally kept locked shut and labelled as such with an appropriate sign which complies with BS5499-10:2014.

It is essential that all closers fulfil the requirements of BS EN 1154: 1997 and are of the correct power rating for the width and weight of the door assemblies (minimum power size 3). They must be fitted according to the manufacturer's instructions and be adjusted so that they are capable of fully closing the door leaf, against any friction imposed by the latch (and smoke seals if fitted) from any position of opening. A variety of closers may be used, subject to compliance with the specifications below:

Face Fixed: Faced fixed overhead door closers (and accessories such as soffit brackets) that have been tested, assessed or otherwise approved by the manufacturer for use on unlatched FD90/FD120 cellulosic door leaves in timber frames (& for FCW mineral cores e.g Dorma TS83V or Briton 2003SES) may be used. Any accessory that is located within the door reveal must have appropriate test or assessment evidence. In addition, where areas of uninsulated glazing are adjacent to the closer, the selected closer type must have been tested on the unexposed face of an uninsulated steel door, or a fully glazed door fitted with uninsulating glass, to demonstrate that the closer does not emit flammable fluids onto the glass face that would otherwise cause integrity failure before the required period of fire resistance.

Concealed Overhead Closers: There are two types of concealed overhead closers suitable for inclusion in FCH90 door assemblies and one for FCW90/120 door assemblies. These are 'slide arm' type closers with the closer morticed into the head of the leaf and a single arm and roller acting in a slide channel morticed into the frame head. The closer is installed in a relatively deep mortice in the door head with the slide channel in a mortice in the frame head.

FCH90: Dorma ITS96 (power size 2-4 model)
FCW90/120: Hoppe UK. AR7383 (power size minimum 3).

These closers having been tested by their manufacturers and subject to the limitations below may be used.

- Inclusion of the intumescent gasket kit as tested and supplied by the Manufacturer, encasing the closer body & closer arm slide body.
- When using in doors with vision panels the top margin between the leaf head and the aperture must be at least 175mm.
- A minimum of 15mm width of intumescent must be residual alongside the arm recess in the head of the frame.

All closers fitted in accordance with the closer manufacturer's instructions must be adjusted so that they are capable of fully closing the door leaf, against any friction imposed by the latch and any smoke or acoustic seals if fitted, from any position of opening.

Bolts

All surface mounted and flush face fixed bolts must be steel or stainless steel.

- Maximum size of flush bolt (FCW only) 250mm long x 38mm wide x 25mm deep.
- The body of the Bolt to be bedded on minimum 1mm thick non-pressure forming intumescent material.
- Flush bolts edge fixed (FCW90/120 only) shall be positioned centrally in the leaf with a minimum of 10mm width of intumescent strip running past either side the body of the bolt.
- Face fixed flush bolts and surface mounted barrel bolts shall be positioned so that there is a minimum of 50mm between the bolt and the door edge.
- Surface mounted barrel bolts shall not exceed 400mm in length but there is no limitation on their width.
- All bolts to be fitted using steel full threaded screws at least 25mm long.

Non-Essential Hardware Items

Push plate, kick plates, etc: Plastic, pvc or metal plates may be surface-mounted to the door assemblies, but if more than 800mm in length by nominally 200mm wide, they must be attached in a way that would prevent them distorting the door leaf, e.g. glued with thermally softening adhesive or screwed with short aluminium screws and fitted in such a way so they will not be prevented from falling away by being trapped under door stops, glazing beads or handle escutcheons etc.

Pull handles: These may be surface fixed to the door assemblies, provided that the fixing points are no greater than 800mm apart. Pull handles that are fixed through the leaf should use clearance holes as close fitting as possible to the non-combustible bolt and be lined with a 1mm non-pressure forming intumescent material. (Through fixing on FCH90/120 not permitted)

Dropseals: FCH: Fully morticed automatic drop threshold seals may be fitted provided that the body of the drop seal does not exceed 35mm high x 15mm wide (excluding fixing flanges). The body of the automatic drop seal must be in aluminium or steel, encased in 1mm non-pressure forming intumescent and morticed central to the thickness of the door core. FCW only NOR810S is permitted.

PLACE THIS SIGNED CERTIFICATE IN THE BUILDING FIRE SAFETY MANUAL

(BS9999:2017 - Section9. Annex H)