



SHARJAH CEMENT & INDUSTRIAL
DEVELOPMENT CO. (PJSC)



Sharjah Cement Factory: Blast Furnace Cement (CEM III B)

Environmental Product Declaration

In accordance with ISO 14025:2006 and EN 15804:2012+A2:2019+AC:2021

EPD Registration Number	S-P-12577
Publication Date	2024-04-15
Valid Until	2029-04-14
Geographical Scope	Global



THE INTERNATIONAL EPD SYSTEM



THE INTERNATIONAL EPD SYSTEM





Content

1	Introduction	2
2	General information	3
2.1	Programme information.....	3
2.2	PCR Information.....	3
2.3	Verification information	4
2.4	LCA information.....	4
3	Product Description and System Boundaries	5
3.1	Product identification and usage	5
3.2	Additional information about EPD	6
3.3	System boundary.....	6
3.3.1	Product stage (A1-A3)	7
3.4	Information sources and data quality.....	1
3.5	Cut off rules	1
3.6	Allocation.....	2
4	Content Declaration.....	3
4.1	Unit processes.....	3
5	Environmental Performance Results.....	5
5.1	LCIA categories.....	5
5.2	Core environmental impact - mandatory indicators.....	7
5.3	Potential environmental impact - additional mandatory indicators.....	8
5.4	Use of resources	8
5.5	Waste production.....	9
5.6	Output flows	9
5.7	Biogenic carbon.....	9
6	Interpretation	10
7	References.....	11



1 Introduction

Sharjah Cement and Industrial Development Co (SCIDC) was incorporated in the United Arab Emirates in 1977. SCIDC manufactures and supplies cement, paper sacks and plastic ropes. The group operates from Sharjah, United Arab Emirates and sells its products globally in the UAE and many other countries. SCIDC produces different cement product types at the "Sharjah Cement Factory". These include grades of Ordinary Portland Cement (OPC), Oil Well Cement (OWC), Blast Furnace Cement (CEM) and Ground Granulated Blast-Furnace Slag (GGBS). For most of these cements, the manufacturing starts with clinker production. This manufactured clinker is mixed with gypsum, flyash, slag and limestone to get different grades.

This EPD is based on a life cycle assessment (LCA) conducted for the SCIDC that evaluates eight cement grades (OPC 42.5N, OPC 52.5N, MSRPC, SRPC, OWC, CEM III A, CEM III B and GGBS). This assessment follows the principles established by ISO 14040, ISO 14044, PCR 2019:14 - 'Construction products' - Version 1.3.3 and c-PCR-001 - 'Cement and Building Lime' (EN 16908:2017+A1:2022) (CEN, 2019; Erlandsson, 2022, 2024; ISO, 2006b, 2006a). The environmental impact indicators selected were based on the International EPD system requirements. They include global warming potential (GWP), acidification potential (AP), abiotic depletion potential (ADP) and others.

This EPD declares the environmental impacts of Blast Furnace Cement (CEM III B) manufactured at the Sharjah Cement Factory. It quantifies the environmental impacts of 1 metric tonne of CEM III B from cradle-to-gate as per requirements of PCR 2019:14 - 'Construction products' - Version 1.3.3.



2 General information

2.1 Programme information

Program	The International EPD® System http://www.environdec.com
Programme operator	EPD International AB Box 210 60, SE-100 31, Stockholm, Sweden
Declaration holder	P. J. Batavia CEO, Sharjah Cement & Industrial Development Co  SHARJAH CEMENT & INDUSTRIAL DEVELOPMENT CO. (PJSC) Sharjah Cement Factory P.O Box 5419 Al Sajaa Industrial Area Dhaid Road, Sharjah, United Arab Emirates
Product	Blast Furnace Cement (CEM III B) This EPD represents the environmental impacts quantified for CEM III B manufactured by Sharjah Cement Factory at Dhaid Road, UAE.
CPC Code	37440
EPD registration number	S-P-12577
Publication date	2024-04-15
Validity date	2029-04-14
Geographical scope	Global
Reference standards	The study fulfils criteria established by PCR 2019:14 - 'Construction products' - Version 1.3.3 and c-PCR-001 - 'Cement and Building Lime' (EN 16908:2017+A1:2022). This study has been conducted per the requirements of ISO 14040, ISO 14044 and EN 15804:2012+A2:2019+AC:2021(CEN, 2019; Erlandsson, 2022, 2024; ISO, 2006b, 2006a).

2.2 PCR Information

Reference PCR	PCR 2019:14 - 'Construction products' - Version 1.3.3 / c-PCR-001 - 'Cement and Building Lime' (EN 16908:2017+A1:2022)
Date of issue	2024-03-01 / 2022-05-18
PCR Moderator	Martin Erlandsson, IVL Swedish Environmental Research Institute



2.3 Verification information

Type of Verification	External independent verification
Third-party verifier	Sunil Kumar C S Chakra4 Sustainability Consulting Services Ivory 501, HM World City, 9 th Phase, J P Nagar Bengaluru, Karnataka - 560108 Email: sunilkumar@chakra4.in

2.4 LCA information

Title	Life Cycle Assessment – Sharjah Cement Factory (OPC 42.5N, OPC 52.5N, MSRPC, SRPC/OWC-A, OWC-G, CEM IIIA, CEM IIIB and GGBS) Third-Party Report (Version 1.4)
Dated	2024-04-05
Author	Mili Jain Founder, Monk Spaces  HR-123/6, Pul Pehlad Pur New Delhi – 110044 Email: mili@monkspaces.com
Reference standards	This study has been conducted as per <ul style="list-style-type: none">• c-PCR-001 - 'Cement and Building Lime' (EN 16908:2017+A1:2022)• PCR 2019:14 - 'Construction products' - Version 1.3.3, 2024• EN 15804:2012+A2:2019+AC:2021 (Sustainability of construction works - Environmental product declarations - Core rules for the product category of construction products)• JRC characterisation factors defined by EF Reference Package 3.0• ISO 14040 - Environmental management - Life cycle assessment Principles and framework• ISO 14044 - Environmental management - Life cycle assessment - Requirements and guidelines



3 Product Description and System Boundaries

3.1 Product identification and usage

<p>Description and Usage</p>	<p>This EPD represents the environmental impacts of Blast Furnace Cements (CEM III B). CEM III B is a controlled blend of Portland Cement and Ground Granulated Blast Furnace Slag. It is recommended for most applications, including civil engineering projects, buildings, and ready-mixed concrete and concrete projects. It is utilised in construction for its enhanced durability, resistance to chloride and sulfate attacks, and lower heat of hydration. The Blast Furnace Cements (CEM III A and CEM III B) also meet the strength requirements of classes 32.5N and 42.5N.</p>		
<p>Chemical Analysis</p>	<p>Test</p>	<p>BS EN 197 - 1: 2011</p>	<p>Result %</p>
	<p>Insoluble residue</p>	<p>5.0% max</p>	<p>0.35</p>
	<p>Magnesium Oxide</p>	<p>5.0% max</p>	<p>3.85</p>
	<p>Sulfate content</p>	<p>4.0% max</p>	<p>2.09</p>
	<p>Equivalent Na₂O</p>	<p>No Limit</p>	<p>0.55</p>
	<p>Loss on Ignition</p>	<p>5.0% max</p>	<p>1.70</p>
	<p>Chloride content</p>	<p>0.10% max</p>	<p>0.04</p>
<p>Physical Tests</p>	<p>Test</p>	<p>Requirement</p>	<p>Result</p>
	<p>Fineness Specific Surface (m²/kg)</p>	<p>Not Specified</p>	<p>420</p>
	<p>Setting Time Minutes</p>		
	<p>Initial</p>	<p>60 minimum</p>	<p>180</p>
	<p>Final</p>	<p>Not Specified</p>	<p>245</p>
	<p>Soundness Le-Chatelier</p>		
	<p>Expansion (mm)</p>	<p>10 maximum</p>	<p>1.00</p>
	<p>Compressive Strength (Mortar Prism (N/mm²))</p>		
	<p>2 Day</p>	<p>10.0 minimum</p>	<p>12.5</p>
	<p>7 Day</p>	<p>16.0 minimum</p>	<p>27.8</p>
	<p>28 Day</p>	<p>42.5 min & 62.5 max</p>	<p>49.5</p>



Manufacturing Location	Sharjah Cement Factory P.O Box 5419 Al Sajaa Industrial Area, Dhaid Road, Sharjah, United Arab Emirates
About Manufacturer	Sharjah Cement and Industrial Development Co, established in 1977, specialises in producing cement, paper sacks, and plastic ropes. Operating from Sharjah, the company distributes its products across the UAE and globally while upholding stringent quality control measures.
Other Certifications	Blast Furnace Cements manufactured by the company adhere to the standards of BS EN 197-1:2011 and ASTM C 595-21 Type IS. The company's products bear the BSI Kitemark, signifying compliance with ISO standards such as ISO 9001-2015 for Quality Management Systems, ISO 14001-2015 for Environmental Management Systems, ISO 45001-2018 for Occupational Health & Safety Management Systems, and ISO 50001-2018 for Energy Management Systems.

3.2 Additional information about EPD

EPDs within the same product category but registered in different EPD programs or not compliant with EN 15804:2012+A2:2019+AC:2021 may not be comparable. For two EPDs to be comparable, they must be based on the same PCR (including the same version number) or be based on fully-aligned PCRs or versions of PCRs; cover products with identical functions, technical performances and use (e.g. identical declared units); have equivalent system boundaries and descriptions of data; apply equivalent data quality requirements, methods of data collection, and allocation methods; apply identical cut-off rules and impact assessment methods (including the same version of characterisation factors); have equivalent content declarations; and be valid at the time of comparison. For further information about comparability, see EN 15804:2012+A2:2019+AC:2021 and ISO 14025.

The EPD owner is the sole owner, liable, and responsible for the EPD.

Declared Unit	1 tonne (1000 kg)
Geographical Scope	Global
Reference Period	The reference period for the primary data (foreground data) used within this EPD is from July 2022 to June 2023. The background data used in the study have been applied through the Ecoinvent v3.8 datasets published in 2021.

3.3 System boundary

The system boundary for this analysis (also detailed in Table 1) has been defined per the requirements of PCR 2019:14 - Construction products - Version 1.3.3 and c-PCR-001 - Cement and Building Lime (EN 16908:2017+A1:2022). Following guidelines established in section 4.3.2 of PCR 2019:14, the production and end-

.....



of-life processes of infrastructure or capital goods used in the product system are excluded. Personnel-related processes, such as the transportation of employees to and from work, are not accounted for (Erlandsson, 2022, 2024).

Since cement fulfils the following three conditions, it is exempt from declaring end-of-life (C1-C4) and benefits beyond the system (D).

- The product or material should be physically integrated with other products during installation,
- The product becomes unidentifiable due to physical or chemical transformation at the end of life.
- The product does not contain biogenic carbon.

Table 1: System boundary of LCA

Stage	Product stage			Construction process stage		Use stage							End-of-life stage				Beyond the system boundary
	Raw material extraction	Transportation	Manufacturing	Transport to customer/site	Installation	Use	Maintenance	Repair	Replacement	Refurbishment	Operational energy use	Operational water use	Deconstruction/demolition	Transport to waste processing	Waste processing	Disposal	
Module	A1	A2	A3	A4	A5	B1	B2	B3	B4	B5	B6	B7	C1	C2	C3	C4	D
Modules declared	X	X	X	ND													ND
Geography	GLO			-	-	-	-	-	-	-	-	-	-	-	-	-	-
Specific data used	95%			-	-	-	-	-	-	-	-	-	-	-	-	-	-
Variation - products	0%			-	-	-	-	-	-	-	-	-	-	-	-	-	-
Variation - sites	0%			-	-	-	-	-	-	-	-	-	-	-	-	-	-

Key: X = included in LCA

ND = module not declared (such a declaration shall not be regarded as an indicator result of zero)

3.3.1 Product stage (A1-A3)

Module A1 indicates the extraction, collection, and production of raw materials required for cement production at the Sharjah Cement Factory, such as limestone, siltstone silica, alumina, coal of different grades, wood, etc. Transporting raw materials to the Sharjah Cement Factory manufacturing unit constitutes module A2. Module A3 quantifies the impact of the activities conducted at the manufacturing unit at Dhaid Road. These activities include the manufacturing of intermediate and finished products. They also include packaging of the finished products.

3.4 Information sources and data quality

The data quality requirements for this study address the following aspects:

- **Data age:** The reference period for the primary data is from July 2022 to June 2023.
- **Geographical coverage:** The primary data was collected from the Dhaid Road (UAE) manufacturing unit.
- **Technology coverage:** The secondary data is based on generic technological processes for each raw material. No efficient processes have been considered for manufacturing the raw material.
- **Representativeness:** The results of the LCA represent the different cement types manufactured by the Sharjah Cement Factory at Dhaid Road (UAE).
- **Consistency:** The study methodology has been uniformly applied to all analysis components. There is no change in the system boundary or quality requirements for any study phase.
- **Reproducibility:** The study is reproducible with access to secondary data sources.

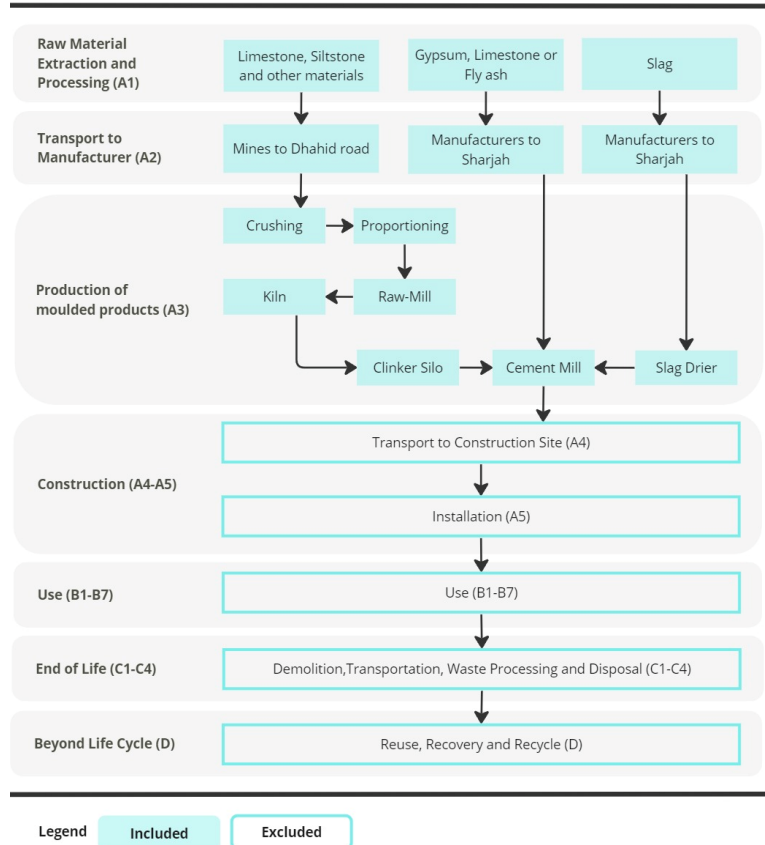

Figure 1: System boundary of LCA

3.5 Cut off rules

As per EN 15804:2012+A2:2019+AC:2021, the cut-off rule indicates that materials that contribute up to 1% of impacts can be excluded if the total exclusions do not exceed 5%. The cut-off rules applied for the assessment are as follows:

- **Mass** – The packaging material used for the cement has been cut off from the assessment since it is less than 0.01% by weight. The detailed calculations for these can be seen in Table 2.
- **Energy** – The alternate fuels (wood, plastic, recycled cloth, spent solvent, rubber and paper) account for 19% of all energy sources. The assessment accounts for 100% of the energy sources used. Since the CPP & WHRS plant is grid-interactive, the emission factors for the regional city grid (Sharjah Electricity, Water and Gas Authority – SEWA) are used.
- **Environmental Significance** - As per ISO 14044, wastes are the producer's responsibility ("polluter pays"), and there is an incentive to use recyclable products that are available burden-free ("cut-off"). For the

.....



assessment, fly ash (externally procured and internally generated at the CPP plant) is available burden-free. This availability means that there are no A1 impacts for the fly ash. The transportation impacts for the fly ash have been accounted for in estimations for A2.

Table 2: Cut-off estimation for packaging products

Material	Capacity	Weight of packaging material	Weight of packaging material per kg of product	Weight % of packaging material by mass
	kg	kg	grams	%
2-ply Kraft Paper	50	0.20	4.00	0.008%
Polypropylene bag	50	0.16	3.20	0.006%
Polypropylene bag	1500	0.23	0.16	0.000%
Polypropylene bag	2000	0.20	0.10	0.000%
Polypropylene bag	2000	0.10	0.05	0.000%

3.6 Allocation

The Sharjah cement manufacturing units manufacture multiple products and intermediate products. The LCA follows a physical approach by co-production. The allocation strategies followed for each of these are as follows:

- **Cement** - The Sharjah Cement Factory reported the composition of each grade of cement. Along with this data, the total raw material procured was reported. The total raw material required was subtracted from the raw material procured to estimate wastage. This wastage was estimated for each raw material and allocated to each cement grade.
- **Clinker** - Sharjah Cement Factory reported monthly quantities of raw material procured, water used, energy consumed and stack emissions separately. These quantities were normalised for the total amount of clinker manufactured in the reference period.
- **Slag Drier** - The raw material consumption, wastage, electricity consumption from the CPP&WHRS plant and natural gas consumption were reported monthly for the reference period. The total quantities were normalised for the total production of dry slag to estimate the environmental impacts.
- **Electricity** - The energy consumed in cement manufacturing (through CPP&WHRS and SEWA) was reported individually for each cement grade. Since the CPP & WHRS plant is grid-interactive, the emission factors for the regional city grid (Sharjah Electricity, Water and Gas Authority - SEWA) were used for the total electricity consumption. This energy causes emissions worth 0.56 kgCO₂e/kWh as per data published by the Ecoinvent 3.8 database.
- **Packaging Plant** - The packaging plant reports quantities of cement packed, types of bags used and energy consumed in packaging. The energy consumed has been allocated to each grade of cement based on the quantities of cement packed. Details regarding the types of bags are explained in Table 2.

4 Content Declaration

The data collected for the reference period was normalised for each metric tonne of cement manufactured by Sharjah Cement Factory. This normalisation has been done through a summation of all inputs and outputs. This normalisation results in the following composition for all products manufactured at the Sharjah Cement Factory, as detailed in Table 3.

Table 3: Unit composition of 1 Tonne of CEM III B (including wastage)

Raw Material Inputs	Quantity	Post-consumer material, weight (%)	Biogenic material, weight (%)	Weight biogenic carbon (kg C / declared unit)
Clinker	350.07	0.02%	0.01%	0.23
Gypsum	37.38	0.00%	0.00%	0.00
Slag	140.07	0.00%	0.00%	0.00
Dry Slag	495.54	0.00%	0.00%	0.00
Total	1023.06	0.02%	0.01%	0.23

4.1 Unit processes

The manufacturing process for the cement (Figure 2) is as follows:

1. The first step is sourcing all the raw materials required for clinker production. This includes limestone, iron ore, siltstone silica, siltstone alumina, bauxite and slags.
2. These raw materials are crushed, pre-homogenised, and passed into the proportioning bins. The crushed materials are mixed and milled to produce a "raw meal".
3. Hot exhaust gases from the kiln preheat raw meal before it enters the kiln. This preheating occurs in a 5-stage cyclone pre-heater, passing the meal through swirling hot flue gases and recovering thermal energy.
4. A combustion chamber at the bottom of the pre-heater is where the coal, natural gas and alternate fuels are added to carry out the calcination.

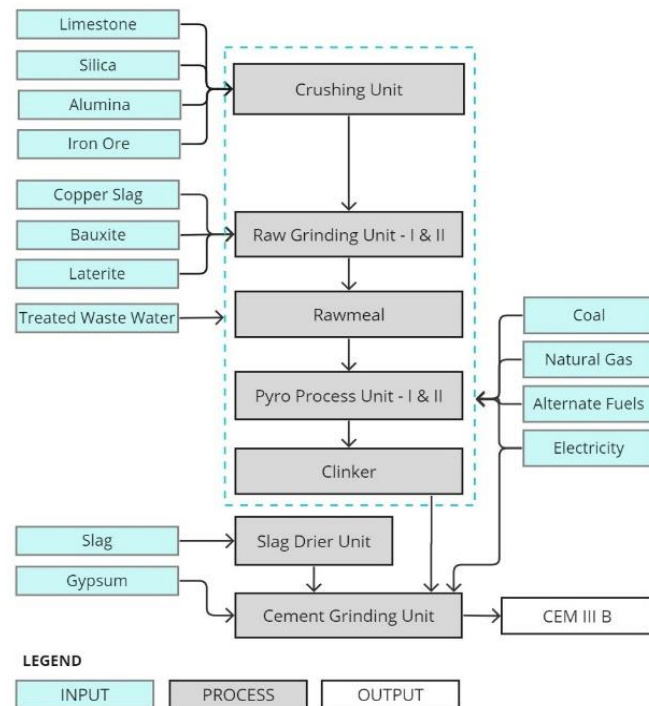

Figure 2: Unit process of CEM III B



5. Pre-calcinated meal enters the kiln and is fired using coal and other alternate fuels. The raw meal converts into clinker due to the intense heat and change in chemical properties. The hot clinker is cooled from the Klin using large quantities of air.
6. Clinker is combined with gypsum and slag in the cement grinding unit. For CEM III B, a proportion of the slag is dried in-house before mixing in the cement grinding unit.



5 Environmental Performance Results

5.1 LCIA categories

The environmental impact quantification categories were selected per PCR 2019:14 - 'Construction products' - Version 1.3.3 and c-PCR-001 - 'Cement and Building Lime' (EN 16908:2017+A1:2022) (Erlandsson, 2022, 2024). The estimated impact results are only relative statements that do not indicate impact categories' endpoints, exceeding threshold values, safety margins or risks.

Environmental Impact Indicators for EN 15804:2012+A2:2019+AC:2021		
Impact category	Indicator	Unit
Climate change - total	Global Warming Potential -Total (GWP-total)	kgCO ₂ e
Climate change - fossil	Global Warming Potential - Fossil Fuels (GWP-fossil)	kgCO ₂ e
Climate change - biogenic	Global Warming Potential - Biogenic (GWP-biogenic)	kgCO ₂ e
Climate change - luluc	Global Warming Potential - Land Use and Land Use Change (GWP-luluc)	kgCO ₂ e
Ozone Depletion	Depletion potential of the stratospheric ozone layer (ODP)	kgCFC ₁₁ e
Acidification	Acidification potential, Accumulated Exceedance (AP)	Mole of H ⁺ e
Eutrophication aquatic freshwater	Eutrophication potential, fraction of nutrients reaching freshwater end compartment (EP-freshwater)	kgPO ₄ ³⁻ e
Eutrophication aquatic marine	Eutrophication potential, fraction of nutrients reaching marine end compartment (EP-marine)	kgNe
Eutrophication terrestrial	Eutrophication potential, Accumulated Exceedance (EP-terrestrial)	molNe
Photochemical ozone formation	Formation potential of tropospheric ozone (POCP)	kgNMVOCe
Depletion of abiotic resources - minerals and metals	Abiotic depletion potential for non-fossil resources (ADP-minerals & metals)	kgSbe
Depletion of abiotic resources - fossil fuels	Abiotic depletion for fossil resources potential (ADP-fossil)	MJ
Water use	Water (user) deprivation potential, deprivation-weighted water consumption (WOP)	m ³



Natural resource use parameters		
Parameter	Acronym	Unit
Renewable primary energy as an energy carrier	PERE	MJ
Renewable primary energy resources as material utilisation	PERM	MJ
Total use of renewable primary energy resources	PERT	MJ
Non-renewable primary energy as an energy carrier	PENRE	MJ
Non-renewable primary energy as material utilisation	PENRM	MJ
Total use of non-renewable primary energy resources	PENRT	MJ
Use of secondary material	SM	kg
Use of renewable secondary fuels	RSF	MJ
Use of non-renewable secondary fuels	NRSF	MJ
Net freshwater use	FW	m ³

Waste categories parameters		
Parameter	Acronym	Unit
Hazardous waste disposed	HWD	kg
Non-hazardous waste disposed	NHWD	kg
Radioactive waste	RW	kg

Output flows		
Parameter	Acronym	Unit
Components for reuse	CRU	kg
Materials for recycling	MR	kg
Materials for energy recovery	MER	kg
Exported energy, electricity	EEE	MJ

Biogenic carbon	
Parameter	Unit
Biogenic carbon content in the product	kg C
Biogenic carbon content in the packaging	kg C



5.2 Core environmental impact – mandatory indicators

Results per declared unit - 1 tonne of CEM III B

Indicator	Unit	A1	A2	A3	Total A1-A3
GWP-total*	kgCO ₂ e	7.59E+00	6.70E+01	3.36E+02	4.10E+02
GWP-fossil	kgCO ₂ e	7.57E+00	6.70E+01	3.36E+02	4.10E+02
GWP-biogenic	kgCO ₂ e	4.04E-03	0.00E+00	5.54E+00	5.54E+00
GWP-luluc	kgCO ₂ e	1.70E-02	4.56E-02	8.38E-03	7.10E-02
ODP	kgCFC ₁₁ e	8.95E-07	1.36E-05	9.89E-06	2.44E-05
AP	molH ⁺ e	9.32E-02	1.92E+00	2.71E+00	4.72E+00
EP-f	kgPO ₄ ³⁻ e	1.91E-04	2.81E-04	1.08E-03	1.55E-03
EP-m	kgNe	2.99E-02	4.74E-01	1.08E+00	1.59E+00
EP-t	molNe	4.12E-01	5.27E+00	1.19E+01	1.75E+01
POCP	kgNMVOCe	8.92E-02	1.37E+00	2.87E+00	4.33E+00
ADP-m	kgSbe	1.37E-03	1.01E-04	3.59E-04	1.83E-03
ADP-f	MJ	9.07E+01	8.65E+02	2.18E+03	3.13E+03
WDP	m ³	2.70E+00	2.76E+00	6.67E+00	1.21E+01

*The indicated values (net values of GWP-total) do not include the biogenic emissions from the incineration of secondary fuels during clinker production. The gross GWP-total (including the emissions from the incineration of secondary fuels at clinker production) is 415.74 kgCO₂e.

Acronyms: GWP-fossil = Global Warming Potential fossil fuels; GWP-biogenic = Global Warming Potential biogenic; GWP-luluc = Global Warming Potential land use and land use change; ODP = Depletion potential of the stratospheric ozone layer; AP = Acidification potential, Accumulated Exceedance; EP-f = Eutrophication potential, fraction of nutrients reaching freshwater end compartment; EP-m = Eutrophication potential, fraction of nutrients reaching marine end compartment; EP-t = Eutrophication potential, Accumulated Exceedance; POCP = Photochemical Oxidants Creation Potential; ADP-m = Abiotic depletion potential for non-fossil resources; ADP-f = Abiotic depletion for fossil resources potential; WDP = Water (user) deprivation potential, deprivation-weighted water consumption



5.3 Potential environmental impact – additional mandatory indicators

Results per declared unit - 1 tonne of CEM III B

Indicator	Unit	A1	A2	A3	Total A1-A3
GWP-GHG	kgCO ₂ e	7.49E+00	6.65E+01	3.33E+02	4.06E+02

The indicator includes all greenhouse gases (kgCO₂e) in the GWP-total. However, it excludes biogenic carbon dioxide uptake, emissions, and biogenic carbon stored in the product. This indicator is thus almost equal to the GWP indicator originally defined in EN 15804:2012+A1:2013.

5.4 Use of resources

Results per declared unit - 1 tonne of CEM III B

Indicator	Unit	A1	A2	A3	Total A1-A3
PERE	MJ	2.72E+00	6.53E+00	1.34E+01	2.27E+01
PERM	MJ	0.00E+00	0.00E+00	0.00E+00	0.00E+00
PERT	MJ	2.72E+00	6.53E+00	1.34E+01	2.27E+01
PENRE	MJ	9.07E+01	8.65E+02	2.18E+03	3.13E+03
PENRM	MJ	7.32E+00	0.00E+00	0.00E+00	7.32E+00
PENRT	MJ	9.81E+01	8.65E+02	2.18E+03	3.14E+03
SM	kg	3.18E-02	3.70E-01	1.29E-01	5.31E-01
RSF	MJ	1.03E-03	1.27E-03	5.13E-04	2.81E-03
NRSF	MJ	0.00E+00	0.00E+00	0.00E+00	0.00E+00
FW	m ³	4.94E-02	6.40E-02	1.62E-01	2.76E-01

Acronyms: PERE = use of primary renewable energy excluding renewable primary energy resources used as raw materials; PERM = Use of renewable primary energy resources used as raw materials; PERT = Total use of renewable primary energy resources; PENRE = Use of non-renewable primary energy excluding non-renewable primary energy resources used as raw materials; PENRM = Use of non-renewable primary energy resources used as raw materials; PENRT = Total use of non-renewable primary energy resources; SM = Use of secondary material; RSF = Use of renewable secondary fuels; NRSF = Use of non-renewable secondary fuels; FW = use of net fresh water



5.5 Waste production

Results per declared unit - 1 tonne of CEM III B

Indicator	Unit	A1	A2	A3	Total A1-A3
HWD	kg	1.42E+01	1.17E+00	2.07E+00	1.75E+01
NHWD	kg	7.50E+00	1.11E+01	4.98E+01	6.83E+01
RWD	kg	4.28E-04	6.05E-03	3.23E-04	6.80E-03

Acronyms: HWD = Hazardous waste disposed; NHWD = Non-hazardous waste disposed; RWD = Radioactive waste disposed

5.6 Output flows

Results per declared unit - 1 tonne of CEM III B

Indicator	Unit	A1	A2	A3	Total A1-A3
CRU	kg	0.00E+00	0.00E+00	0.00E+00	0.00E+00
MR	kg	0.00E+00	0.00E+00	0.00E+00	0.00E+00
MER	kg	0.00E+00	0.00E+00	0.00E+00	0.00E+00
EEE	MJ	0.00E+00	0.00E+00	0.00E+00	0.00E+00

Acronyms: CRU = Components for reuse; MR = Materials for recycling; MER = Materials for energy recovery; EEE = Exported energy, electricity

5.7 Biogenic carbon

Results per declared unit - 1 tonne of CEM III B

Biogenic Carbon Content	Unit	Quantity
Biogenic carbon content in the product	kg C	2.27E-01
Biogenic carbon content in the packaging	kg C	0.00E+00



6 Interpretation

Parameter	Interpretation
Global Warming Potential (GWP)	The cradle-to-gate (A1-A3) GWP-Total of the CEM III B is 410.2 kgCO ₂ e. This quantity includes GWP-fossil, GWP-biogenic, and GWP-luluc, with module A3 contributing 82% of the GWP-Total.
Ozone Depletion Potential (ODP)	Ozone Depletion Potential (ODP) measures the potential impact of chloro-fluoro-carbons (CFCs) and chlorinated hydrocarbons (HCs) on depleting the ozone layer. For CEM III B, the ODP is negligibly small.
Acidification Potential (AP)	The Acidification Potential indicator accounts for soil, ground and surface water acidification. The acidification potential during the cradle-to-gate stage for CEM III B is 4.7 molH ⁺ e.
Eutrophication Potential (EP)	Eutrophication Potential (EP) measures the growth of nutrients in water and soil, assessed across freshwater, marine, and terrestrial ecosystems. For CEM III B, terrestrial ecosystems exhibit the highest level of nutrient excess at 17.5 molNe. In contrast, marine ecosystems contribute 1.6 kgNe, while freshwater ecosystems show no significant quantity of excessive nutrients.
Photochemical Oxidants Creation Potential (POCP)	The POCP scale quantifies the ability of volatile organic compounds (VOCs) to produce ground-level ozone. The cradle-to-gate POCP is 4.3 kgNMVOCe.
Abiotic Depletion Potential (ADP)	The ADP for fossils for the cradle-to-gate estimation of CEM III B is 3131.0 MJ. The ADP for minerals and metals is insignificantly small.
Water Depletion Potential (WDP)	The water footprint of a product is the amount of water consumed or polluted in all processing stages of its production. The WDP of the CEM III B for A1-A3 is 12.1 m ³ .



7 References

- CEN. (2019). *Sustainability of construction works - Environmental product declarations - Core rules for the product category of construction products (EN 15804:2012+A2:2019+AC:2021)*. <https://www.en-standard.eu/csn-en-15804-a2-sustainability-of-construction-works-environmental-product-declarations-core-rules-for-the-product-category-of-construction-products>
- Erlandsson. (2022). *c-PCR-001 Cement and Building Lime(EN 16908:2017+A1:2022)*. <https://api.environdec.com/api/v1/EPDLibrary/Files/56e3eaa9-6faf-436c-c231-08da3724454d/Data>
- Erlandsson. (2024). *Product Category Rules 2019:14 Construction Products Version 1.3.3*. <https://api.environdec.com/api/v1/EPDLibrary/Files/cfb8786b-c166-4d25-02ed-08dc38ee8ac8/Data>
- ISO. (2006a). *Environmental management - Life cycle assessment - Principles and framework (ISO 14040)*.
- ISO. (2006b). *Environmental management- Life cycle assessment - Requirements and guidelines (ISO 14044:2006)*.



**SHARJAH CEMENT & INDUSTRIAL
DEVELOPMENT CO. (PJSC)**