

Environmental Product Declaration



THE INTERNATIONAL EPD SYSTEM



In accordance with ISO 14025:2006 and EN 15804:2012+A2:2019/AC:2021 for:

Pre-painted Galvanized Iron (PPGI)

from

SeAH Coated Metal

SeAH Coated Metal

Programme:	The International EPD® System, www.environdec.com
Programme operator:	EPD International AB
EPD registration number:	S-P-09708
Publication date:	2023-08-22
Revision date (version 1.1):	2023-11-08
Valid until:	2028-08-22

An EPD should provide current information and may be updated if conditions change. The stated validity is therefore subject to the continued registration and publication at www.environdec.com

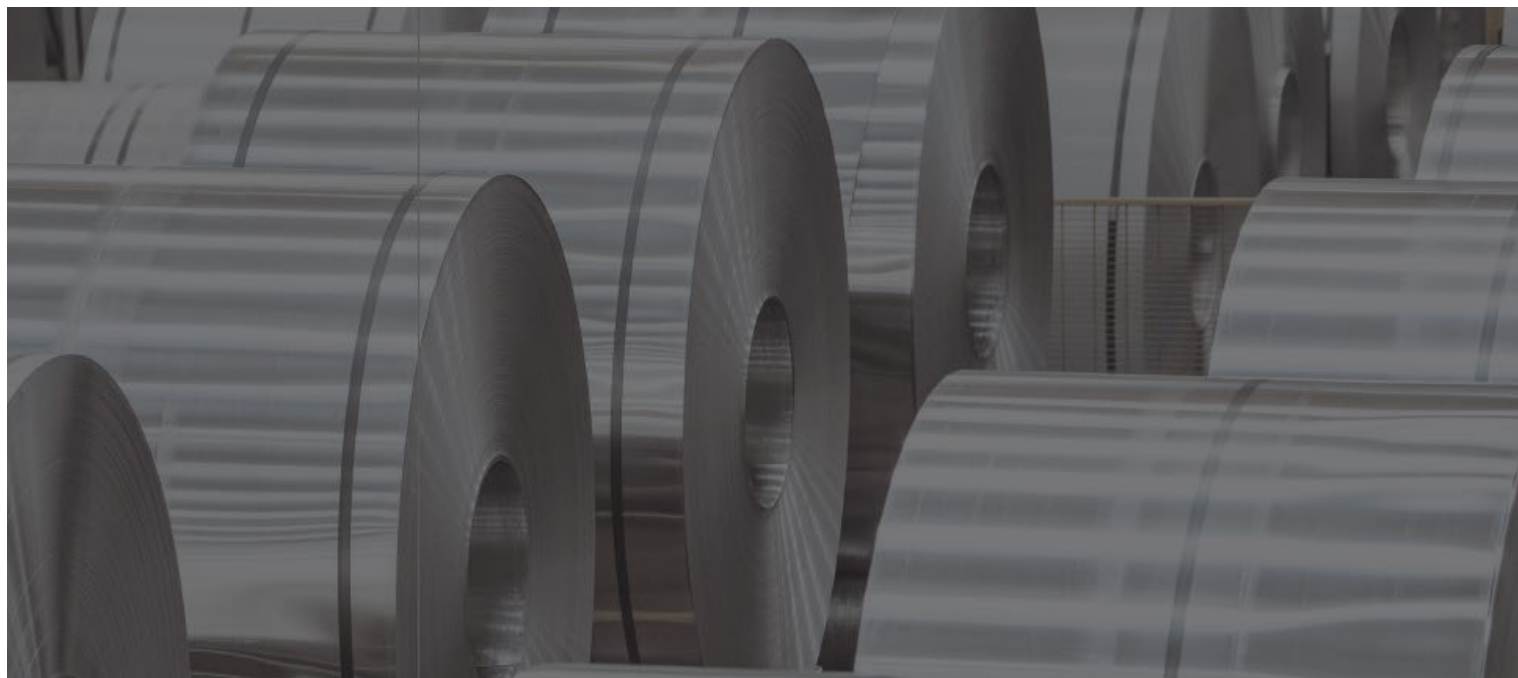

General information

Programme information

Programme:	The International EPD [®] System
Address:	EPD International AB Box 210 60 SE-100 31 Stockholm Sweden
Website:	www.environdec.com
E-mail:	info@environdec.com

Accountabilities for PCR, LCA and independent, third-party verification
Product Category Rules (PCR)
CEN standard EN 15804 serves as the Core Product Category Rules (PCR)
Product Category Rules (PCR): Construction products 2019:14, version 1.3.0 and UN CPC code 412
PCR review was conducted by: <i><name and organisation of the review chair, and information on how to contact the chair through the programme operator></i>
Life Cycle Assessment (LCA)
LCA accountability: JongHyuk Lee (Associate), SeAH Coated Metal
Third-party verification
Independent third-party verification of the declaration and data, according to ISO 14025:2006, via: <input checked="" type="checkbox"/> EPD verification by individual verifier Third-party verifier: Ik Kim, Smarteco,  Approved by: The International EPD [®] System

The EPD owner has the sole ownership, liability, and responsibility for the EPD.

EPDs within the same product category but registered in different EPD programmes, or not compliant with EN 15804, may not be comparable. For two EPDs to be comparable, they must be based on the same PCR (including the same version number) or be based on fully-aligned PCRs or versions of PCRs; cover products with identical functions, technical performances and use (e.g. identical declared/functional units); have equivalent system boundaries and descriptions of data; apply equivalent data quality requirements, methods of data collection, and allocation methods; apply identical cut-off rules and impact assessment methods (including the same version of characterisation factors); have equivalent content declarations; and be valid at the time of comparison. For further information about comparability, see EN 15804 and ISO 14025.

Company information

Owner of the EPD: SeAH Coated Metal

Contact:

- Phone: +82-63-469-8500
- Address: #241, Jayu-ro, Gunsan-City, Jeonbuk 54004, Republic of Korea
- Contact: Chang-ju Lee (Team Leader), changju1@seah.co.kr

Description of the organisation:

Starting with the pre-painted steel sheet business in 1998 and completing the cold-rolling production line in 2005, SeAH Coated Metal has led the steel industry as an excellent comprehensive cold-rolling plant. We have now grown into Korea's best pre-painted metal sheet manufacturer both in name and reality with the production capacity for luxurious goods by rationalizing 2CCL in 2017, revamping CGL to dual pot in 2021, and completing 3CCL in 2022.

SeAH Coated Metal provides customers with a wide range of products, including galvanized steel, aluminum-zinc alloy coated steel, pre-painted steel sheet for luxury building materials and high-end home appliances, and pre-painted aluminum sheets. Furthermore, through overseas exports, we are proudly proving our capabilities with excellent products in the world market.

All employees of SeAH Coated Metal are actively participating in safety, health, environment, and compliance management to fulfill their roles and duties as a social enterprise based on the spirit of respect for human beings.

We have acquired environmental management system ISO 14001, health and safety management system ISO 45001, and HB mark certification for eco-friendly building materials to continuously improve safety and environment. We legally comply with working hours and working conditions, and thoroughly prevent industrial accidents. In addition, we are making efforts to continuously reduce greenhouse gas emissions by disclosing carbon emission information of major products.

SeAH Coated Metal pursues fair and transparent competition based on an ethical corporate culture that adheres to basics and principles and complies with laws and regulations. Through strict and systematic compliance management that meets the global standard, we acquired the ISO 37301 certification for the compliance management system for the first time in the steel industry.

In the future, SeAH Coated Metal will change the world beautifully with leading and continuous innovation.

Product-related or management system-related certifications: ISO 9001, ISO 14001

Name and location of production site(s):

Gunsan (Head Office) : #241 Jayu-ro, Gunsan-si, Jeollabuk-do

Product information

Product name: *Pre-painted Galvanized Iron (PPGI)*

Product identification:

SeAH CM's color steel plate is a product that has been painted before processing, and is produced through complete pretreatment, several painting and heat treatment drying by the latest painting method based on Galvanized iron steel plates. It has excellent adhesion and excellent processability that does not cause peeling of the film even when roll forming, bending, and pressing due to its beautiful surface, so it can be widely used in various applications such as building materials, assembly metals, and home appliances. It also boasts high-quality products such as surface beauty and excellent painting properties due to the latest facilities and abundant operational technology of technical personnel. In particular, SeAH CM's excellent quality and beautiful surface products can be applied to various applications such as construction, electric and electronic sectors, and automobiles. This product is produced according to KS D 3520, JIS G 3312, ASTM A755-A792, and EN 10169. SeAH CM has obtained standard certification from various countries such as KS Korea, JIS Japan, TISI Thailand, C3 Germany, and BIS India. In addition, SeAH CM has obtained HB certification from the Korea Air Cleaning Association.

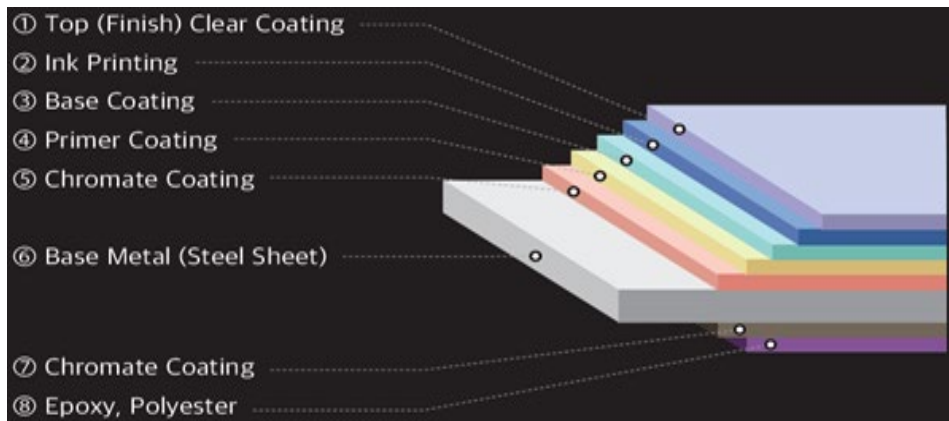

Product specification:

The specifications of the product are described in Table 1, and 2. The two tables shows the result of inspection for appearance and size.

Table 1 Inspection results 1

Inspection item	Conditions	Quality standards				
appearance	Visual inspection	The surface of the product shall be free from any defects in use such as contamination, hole, scratch, imprint, stripes, stains, peeling, etc.				
Product Thickness (mm)	Micrometer 1/1,000mm	Display Thickness	Based on product width (KS-domestic standard)			
			Less than 630	630 ~ 1,000	1,001 ~ 1,250	1,251 ~ 1,320
		Less than 0.25	+0.08 ~ -0.03	+0.08 ~ -0.03	+0.08 ~ -0.03	+0.08 ~ -0.03
		0.26 ~ 0.40	+0.09 ~ -0.04	+0.09 ~ -0.04	+0.09 ~ -0.04	+0.09 ~ -0.04
		0.41 ~ 0.60	+0.10 ~ -0.05	+0.10 ~ -0.05	+0.10 ~ -0.05	+0.10 ~ -0.05
		0.61 ~ 0.80	+0.10 ~ -0.06	+0.10 ~ -0.06	+0.10 ~ -0.06	+0.10 ~ -0.06
		0.81 ~ 1.60	+0.10 ~ -0.08	+0.10 ~ -0.08	+0.10 ~ -0.08	+0.10 ~ -0.08
Product Width	a tape measure	0 mm to +4 mm (priority to demand requirements).				
diagonal tolerance (SHEET PRODUCT)	a tape measure	length Width	Less than 2,000 mm	2,000 mm or more		
		Less than 1,000	1.0 mm or less	1.0 mm or less		
		More than 1,000	1.5 mm or less	2.0 mm or less		
Shape	Steel ruler (tape : period measure, Taper gauge : wave length measurement)	Inspection Items	allowable tolerance	a particular matter		
		Flatness	4/1,000 mm or less	Gr-E material 7/1,000 mm or less		

[REMARK]

The flatness is basically 4/1,000 mm or less, but the spacing and wavelength can be determined by calculating the ratio. ex) 2/500 mm, 1.2/300 mm or less, etc.

Table 2 Inspection results 2

Inspection item	Conditions	Combined Criteria	
Color difference	ΔE	Within 1.20 M/C ΔE (within 1.50 METALIC ΔE)	
	Same LOT color difference	Within ΔE 0.30 compared to the same LOT product (It refers to the same color LOT produced on the same day. ROLL replacement or not)	
	Color difference between different LOTs	Within ΔE 0.50 compared to LOT product requested (when demand is requested) (It refers to the same color LOT produced on the other day. ROLL replacement or not) If the demand matches the requested LOT, the color difference compared to M/C is irrelevant.	
a coating	DJH / Micro meter	Designated coating film $\pm 3 \mu m$ (However, for MATT or WRINKLE products, Dryness on the back of the M/C by color depends on the film thickness range.)	
gloss	60°	Product Gloss 71% or higher	± 10
		Product Gloss 51% to 70%	± 7
		Product Gloss 50% or less	± 5
Pencil hardness	Pencil (Mitsubishi)	H or higher (However, the pencil hardness standard may vary depending on the gloss)	
M.E.K	a round trip up and down(round trip distance 100-150 mm)	50 or more times (Metallic shall be 20 or more times, depending on the characteristics of the paint) May vary, in principle, shut down when the primer is visible)	
C.C.E	10 X 10 X 6 mm	5 points or more (no peeling of coating)	

Bending	180°	0.4 mm or less (2T BENDING)	4 points or more (no peeling of coating)
	180°	0.6 mm or greater (3T BENDING)	4 points or more (no peeling of coating)
Shock resistance		½ "500 g X 500 mm	5 points or more (no peeling of coating)
Chemical resistance	Acid resistance	5% HCl (hydrochloric acid)	24 HR (However, high metallic and organic pigments may not be guaranteed)
	Alkaline resistance	5% NaOH (Sodium Hydroxide)	24 HR (However, high metallic and organic pigments may not be guaranteed)
Standard for chemical resistance		RUST, CRACK, swelling, discoloration: 4 points or more, gloss retention: 70% or more, ΔE 1.0 or less	
Salt Spray resistance(5% NaCl)		BLISTER: 4 points or higher	500 Hr
		RUST : 4 points or higher	
		SCRIBE Penetration Distance: Within 2 mm of one side	

Dry Film Thickness

- Top Side : Primer 5~10^μ , Finish 10~35^μ
- Back Side: Epoxy 5~10^μ

Packing & Marking

- Coils(for Domestic Market)

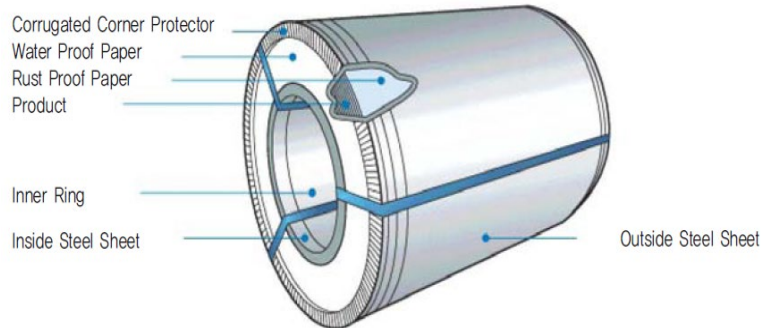

Figure 1 Product packing

- Coils(for Overseas Market)

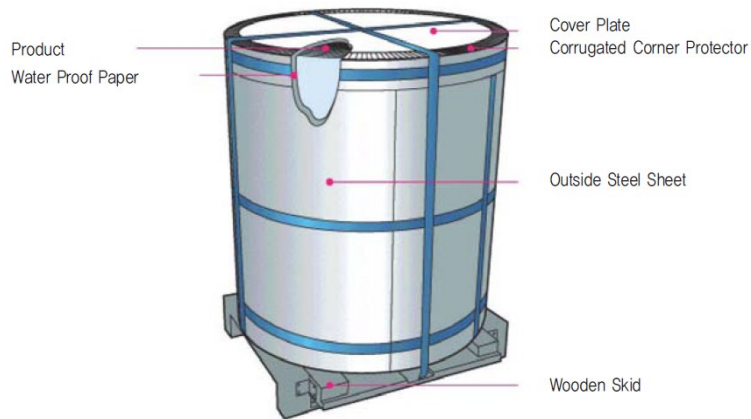

Figure 2 Product packing

- Sheet

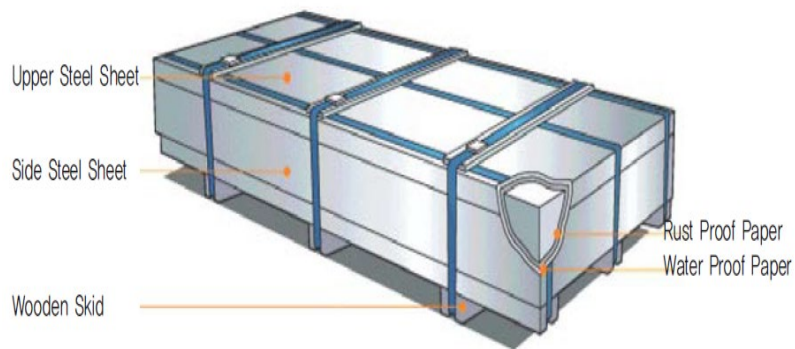

Figure 3 Product packing

- Label (for example)

PREPAINTED HOT DIP GALVANIZED STEEL SHEETS AND COIL			
SIZE 0.0185 X 44 X C		PPGI 	
PROD. NO. EN4C854C01			
SPEC. ASTM A755-A653 CS TYPE A	ZINC COATING Z120	DATE 2023-05-09	GRADE A
COLOR(TOP) WHITE(W983)	COLOR(BACK) GREY(NB86)	LENGTH/SHEETS 1,410 M (4,626 ft)	
WEIGHT(NET WT.) 5,860 Kg (12,919 lb)	WEIGHT(GROSS WT.) 5,960 Kg (13,140 lb)	DEST NET WEIGHT :	
SēAH 5004060-004-05860-EN4C854C01-1		MADE IN KOREA	

Figure 4 Product marking example

Product Application:

- Exterior material : building, office hotel, department store, gym, building canopy, plant panel, poultry farming, hog raising, the outer part of a barn, cool roofing
- Interior material : wall, ceiling panels
- Container, large signboard, traffic signs, furniture
- Home appliances



Figure 5 Product Application

Manufacturing Process:

It consists of five processes. Details are shown in the Figure 6 and Table 3.

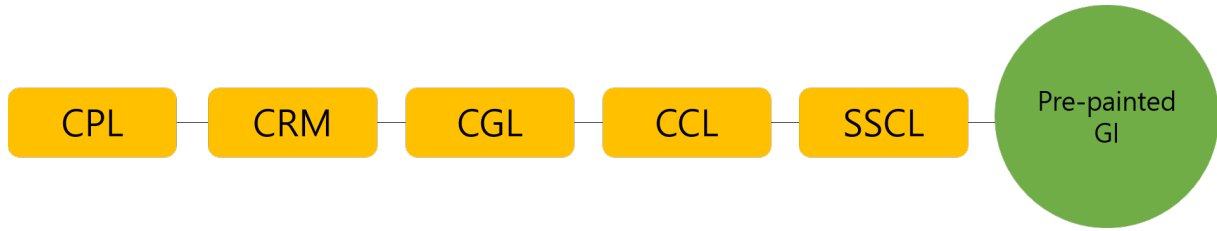

Figure 6 Manufacturing process flow

Table 3 Manufacturing process of Pre-painted GI

Process	Description
CPL (Continuous Pickling Line)	Dip in and spray the hydrochloric acid solution on the steel coil to remove the scale. Remove the remaining hydrochloric acid solution by rinsing water.
CRM (Cold Rolling Mill)	Full Hard (F/H) is produced by rolling the coil in a mill stand by a single stand six-stage reversible cooled rolled method.
CGL (Continuous Galvanizing Line)	Spray the raw material coil with a hot alkali solution to remove foreign substances from the surface. Chemical degreasing with an alkali solution and physical degreasing with brushing. Heat and anneal the strip. After plating molten zinc on the strip surface, adjust the plating thickness with air blowing and cool it. Roll to MAX 700TON and stretch. Chromium is applied to form a film and then dry. Oiling can be done as needed.
CCL (Continuous Color Line)	CCL process consists of 1CCL process and 2CCL process Both processes have similar processing flows. For 1CCL, Carry out 5 steps of cleaning, brushing, rinsing, hot water rinsing, final rinsing on the coil. Coating the chemical liquid and dry it. Do Primer coating and dry in a hot air circulating skillet. Do Finish coating and dry in a hot air circulating soboro. A strip with appropriate tension is obtained after passing through the small rolls. For 2CCL, all processes are the same as 1CCL, but pattern printing is possible. Proper surface treatment is applied to the film and the iron plate, and heat and pressure are applied simultaneously to adhere them. Various patterns are implemented by transferring ink to an iron plate. Coat and dry in the desired color. The pattern is transferred by applying pressure to the surface of the iron plate with a leather pattern and a water drop pattern. Pass the strip with appropriate tension through the small rolls and wind it up.
SSCL (Shear Slitter Combi Line)	Cut the coil into several narrow widths in the lateral direction (slitting), and cut the object by applying a pair of forces in parallel opposite to the cross-section of the object (shear)

A detailed 1CCL process diagram is shown in Figure 7.

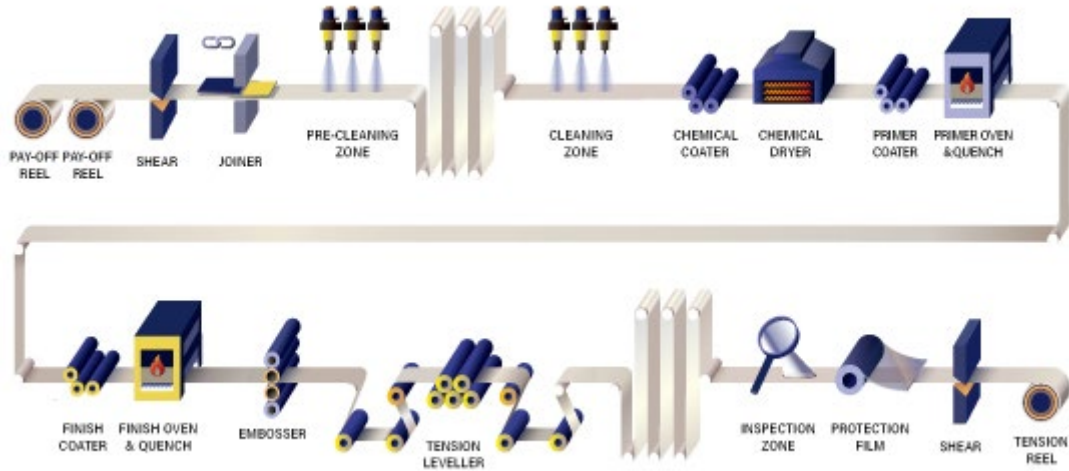

Figure 7 1CCL process

UN CPC code: 412 Products of iron or steel

Other codes for product classification: KS D 3520, JIS G 3312, ASTM A755-A792, and EN 10169

Geographical scope: Republic of Korea

LCA information

Declared unit: 1 tonne of PPGI (Pre-painted Galvanized Iron)

Time representativeness: Fiscal year 2022, 12 months from January to December

Database(s) and LCA software used: Gabi 10 software system. Gabi database provides the life cycle inventory data for several of the raw and process materials obtained from upstream system. The database used are professional database, Full US extension database XVII and Ecoinvent 3.8.

Electricity Mix: KR: market for electricity, low voltage ecoinvent 3.8 (2019) is used in this EPD study and it has climate change impact – total, 0.70kg CO₂/kWh according to EN15804+A2(EF 3.1).

Description of system boundaries: “Cradle to gate with options, module C1-C4 and module D” (A1–A3 + C + D) is selected for the LCA study according to EN 15804 Section 5.2. The detailed information for manufacturing process from Module A3 is described in the product information above.

System diagram:

Figure 8 is a system diagram and Table 4 explains relevant life cycle stages and the definition of each module. The infrastructure and capital goods are excluded in the system boundary.

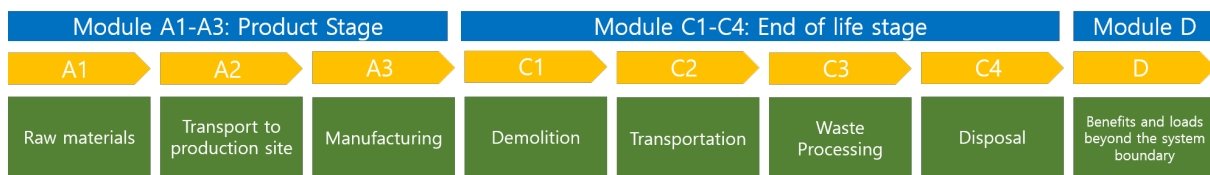

Figure 8 System diagram

Table 4 System boundary and Life Cycle

EPD Module	Life Cycle Stages	Definition
A1	Raw Material Supply	<ul style="list-style-type: none"> - Extraction and processing of raw materials (e.g. mining processes) and biomass production and processing (e.g. agricultural or forestry operations) - Reuse of products or materials from a previous product system - Processing of secondary materials used as input for manufacturing the product, but not including those processes that are part of the waste processing in the previous product system - Generation of electricity, steam and heat from primary energy resources, also including their extraction, refining and transport - Energy recovery and other recovery processes from secondary fuels, but not including those processes that are part of waste processing in the previous product system
A2	Transport to manufacturer	Transportation up to the factory gate and internal transport
A3	Manufacturing	<ul style="list-style-type: none"> - Production of ancillary materials or pre-products - Manufacturing of products and co-products - Manufacturing of Packaging

C1	De-construction demolition	deconstruction, including dismantling or demolition, of the product from the building, including initial on-site sorting of the materials
C2	Transport	transportation of the discarded product as part of the waste processing, e.g. to a recycling site and transportation of waste e.g. to final disposal.
C3	Waste processing	waste processing e.g. collection of waste fractions from the deconstruction and waste processing of material flows intended for reuse, recycling and energy recovery. Waste processing shall be modelled and the elementary flows shall be included in the inventory. Materials for energy recovery are identified based on the efficiency of energy recovery with a rate higher than 60 % without prejudice to existing legislation. Materials from which energy is recovered with an efficiency rate below 60% are not considered materials for energy recovery.
C4	Disposal	waste disposal including physical pre-treatment and management of the disposal site.
D	Reuse-Recovery- Recycling-potential	the environmental benefits or loads resulting from reusable products, recyclable materials and/or useful energy carriers leaving a product system e.g. as secondary materials or fuels.

Table 5 describes the modules declared, geographical scope, share of specific data.

Table 5 Modules declared and geographical scope

	Product stage			Constructi on process stage		Use stage							End of life stage				Res our ce rec ove ry sta ge
	Raw material supply	Transport	Manufacturing	Transport	Construction installation	Use	Maintenance	Repair	Replacement	Refurbishment	Operational energy use	Operational water use	De-construction demolition	Transport	Waste processing	Disposal	
Module	A1	A2	A3	A4	A5	B1	B2	B3	B4	B5	B6	B7	C1	C2	C3	C4	D
Modules declared	X	X	X	-	-	-	-	-	-	-	-	-	X	X	X	X	X
Geography	KR	KR	KR	-	-	-	-	-	-	-	-	-	GL O	GL O	GL O	GL O	GL O
Specific data used	>90%																

X: Module declared

-: Module not declared (such a declaration shall not be regarded as an indicator of a zero result)

Scenarios for module C1-C4 and D

- De-construction demolition (C1) : Energy consumption of a demolition process is on average 10kWh/m2 (Bozdog, Ö & Seçer, M. 2007). The average mass of a reinforced concrete building is about 1000 kg/m2. Therefore, energy consumption during demolition is 10kWh per declared unit, 1 metric ton. A conservative assumption has been made that the energy consumed during demolition of a steel building is the same as that of a concrete building. The source of energy is diesel fuel used by industrial equipments.
- Transport (C2) : It is assumed that 100% of the waste is collected and transported to the waste treatment centre. Transportation distance to the waste treatment centre is assumed as 300 km and the transportation method is assumed to be lorry, Euro 0-6 mix.
- Waste processing (C3) : Approximately 95% of steel is assumed to be recycled based on World Steel Association, 2020.
- Disposal (C4) : It is assumed that the remaining 5 % of steel is buried to landfill for final disposal.
- Reuse-Recovery-Recycling-potential (D) : During the recycling process, 95% of the end-of-life product is converted into recycled steel.

Excluded life cycle stages: Use phase are not included following the PCR.

Cut-Off Rule: Criteria were set out in the original study for the recording of material flows and to avoid the need to pursue trivial inputs/outputs in the system. Life cycle inventory data shall according to EN 15804 include a minimum of 95% of total inflows (mass and energy) per module. In order to conservatively calculate the environmental impact, it was intended to consider the environmental impact of all energy.

It is too hard to apply the cut-off criteria per module since the process flow is very complex due to the characteristics of steel production. Therefore, the scope of data collection is determined by calculating the cut-off criteria for each unit process, not based on the product system.

some materials within the cut-off criteria are included for environmental relativity because the mass inflows such as plating material (zinc and chromium) and paint may have a crucial environmental impact. There are a few exclusions from the total mass inflows when it is difficult to find their LCA DB. Inflows not included in the LCA shall be documented in the assumptions and limitations.

Assumptions and Limitations

- Raw material: All the plating materials in the production were considered as the inflows such as zinc, chromium and paint. When calculating the mass balance between inflows and outflows per module, the contribution of the liquid materials was calculated by applying a theoretical ratio for the steel plate. The inflows of raw material excluded according to the cut-off rule are as follows; protective film, chromium solution, chromium-free solution, degreaser, metal rolling oils, machine oils, hydraulic oils
- Waste: During the manufacturing stage, Module A3, the outflow does not include the waste, which is not directly related to the production. The excluded waste is the packaging of the raw material, construction wastes, wood, glass and so on. The secondary database for waste treatment was categorized into municipal waste and hazardous waste. The distance from the manufacturing plant to the place of waste treatment is set to 30km considering the site-specific data.
- Product: All kinds of scrap and dross produced from manufacturing stage are sold with considerable price and amount. Therefore, the scrap cannot be treated as waste but as co-product which needs allocation.
- Allocation: It is too hard to apply the cut-off criteria per module since the process flow is very complex due to the characteristics of steel production. Therefore, the scope of data collection is determined by calculating the cut-off criteria for each unit process, not based on the product system.

Allocation Rules:

Allocation is required if some material, energy, and waste data cannot be measured separately for the product under investigation. PCR 2019:14 Sections 4.5.1 and 4.5.2 provide guidance on the allocation of co-products and waste, respectively, and as such are further specifications of Sections 6.4.3.2 and 6.4.3.3 of EN 15804. EN 15804 defines co-products as “any of two or more marketable materials, products or fuels from the same unit process, but which is not the object of assessment” and waste as a “substance or object which the holder discards or intends or is required to discard”.

Pre-consumer scrap, leaving the product system from modules A1-A3, shall be allocated as a co-product, see Section 4.5.1. Because no omission of inputs or outputs through allocation shall be done, scrap entering a product system shall come with an environmental burden if it originated from modules A1- A3 of a previous product system, and the calculation of this burden shall be based co-product allocation.

The allocation of co-products follows the PCR 2019:14 and Section 6.4.3.2 in EN15804 in the following order;

1. Allocation should be avoided.
2. Allocation should be based on physical properties when (i) there is a relevant underlying physical relationship between the products and co-products, and (ii) the difference in revenue per mass (or per energy unit in case of electricity, heat or similar) from the products and co-products is low.
3. In all other cases, allocation shall be based on economic values of the products and co-products when they leave the unit process.

PCR 2019:14 does not provide clear standard for how much difference in revenue in order to proceed economic allocation. There should be specific value for the difference in revenue. Therefore, the EPD study adopted the standard from UL Product Category Rules (PCR) Guidance for Building Related Products and Services Part A: Life Cycle Assessment Calculation Rules and Report Requirements. The standard are as follows;

“Allocation shall be based on economic values when the difference in revenue from the co-products is high. Contributions to the overall revenue of the order of 1% or less is regarded as very low. A difference in revenue of more than 25% is regarded as high.”

Due to the nature of steel products, scraps occur in each unit process. If the revenue of scrap (price x production weight) from unit process is more than 1% of total revenue, economic allocation was applied because the difference between revenues is more than 25%.

Content information

Product components	Weight, kg	Post-consumer material, weight-%	Biogenic material, weight-% and kg C/kg
Hot Rolled Steel Plate	980.4	0	0
Paint	13.4	0	0
Etc	6.3	0	0
TOTAL	1000	0	0
Packaging materials	Weight, kg	Weight-% (versus the product)	Weight biogenic carbon, kg C/kg
SKID (Wood 98%, rubber 2%)	7.010	7.01E-03	5.00E-01
Paper pipe (Paper)	9.684	9.68E-03	3.50E-01
Clip, Packing materials (Galvanized Iron)	9.574	9.57E-03	0
Wrapping paper (Paper 70%, Polyethylene 30%)	1.387	1.39E-03	3.50E-01
Tape, Protector (Low density polyethylene)	0.462	4.62E-04	0
Hoop (Full Hard)	1.724	1.72E-03	0
TOTAL	29.842	2.98E-02	

Dangerous substances from the candidate list of SVHC for Authorisation	EC No.	CAS No.	Weight-% per functional or declared unit
None			

Environmental Information

The LCIA results for 1 tonne of PPGI are given.

Potential environmental impact – mandatory indicators according to EN 15804

PARAMETER		UNIT	A1	A2	A3	Total A1 – A3	C1	C2	C3	C4	D
Global warming potential (GWP)	TOTAL	kg CO ₂ eq.	261E+03	4.03E+01	1.17E+02	276E+03	3.67E+00	8.38E+01	8.01E+00	2.59E-01	-1.64E+03
	Fossil	kg CO ₂ eq.	263E+03	3.95E+01	1.15E+02	278E+03	3.67E+00	8.20E+01	7.90E+00	2.58E-01	-1.65E+03
	Biogenic	kg CO ₂ eq.	-1.98E+01	6.03E-01	1.94E+00	-1.73E+01	0	1.34E+00	8.90E-02	2.43E-04	9.73E+00
	Land use and land transformation	kg CO ₂ eq.	1.45E-01	2.13E-01	1.97E-03	3.59E-01	0	4.74E-01	2.39E-02	2.43E-04	-2.20E-01
Ozone Depletion	kg CFC-11 eq.	4.77E-05	7.18E-11	-4.78E-08	4.77E-05	2.05E-10	5.09E-12	2.60E-06	1.07E-07	2.22E-09	
Acidification	Mole of H ⁺ eq.	1.28E+01	3.23E-01	1.83E-01	1.33E+01	5.52E-02	5.82E-01	6.58E-02	2.48E-03	4.04E+00	
Eutrophication aquatic freshwater	kg P eq.	1.49E-01	1.15E-04	3.61E-05	1.49E-01	2.26E-06	2.54E-04	8.40E-04	2.41E-05	-3.84E-04	
Eutrophication marine	kg N eq.	-6.92E+00	1.55E-01	3.89E-02	-6.73E+00	2.22E-02	2.88E-01	2.32E-02	8.62E-04	-6.48E-01	
Eutrophication terrestrial	Mole of N eq.	1.65E+01	1.71E+00	4.24E-01	1.87E+01	2.43E-01	3.19E+00	2.53E-01	9.42E-03	-5.81E+00	
Formation of photochemical ozone	kg NMVOC eq.	6.88E+00	3.13E-01	2.42E+00	9.62E+00	6.47E-02	5.42E-01	7.30E-02	2.74E-03	-2.63E+00	
Depletion of abiotic resources - minerals & metals	kg Sb eq.	2.93E-02	3.20E-06	7.10E-07	2.93E-02	0	7.13E-06	2.23E-05	6.01E-07	-9.34E-03	
Depletion of abiotic resources - fossil	MJ	3.37E+04	5.44E+02	2.40E+02	3.45E+04	1.02E+02	1.14E+03	1.85E+02	7.38E+00	-1.64E+04	
Water Use	m ³ eq.	4.98E+02	3.42E-01	2.41E+00	5.01E+02	0	7.62E-01	6.62E+00	3.39E-01	-1.11E+02	

Additional mandatory and voluntary impact category indicators

Results per functional or declared unit							
Indicator	Unit	A1-A3	C1	C2	C3	C4	D
GWP-GHG ¹	kg CO ₂ eq.	2.78E+03	3.67E+00	8.24E+01	7.92E+00	2.59E-01	-1.65E+03

Use of resources according to EN 15804

PARAMETER	UNIT	A1	A2	A3	Total A1 – A3	C1	C2	C3	C4	D
Use of renewable primary energy (PERE)	MJ	8.17E+02	2.90E+01	3.88E+00	8.50E+02	0	6.45E+01	2.29E+00	6.40E-02	6.48E+02
Primary energy resources as raw materials (PERM)	MJ	0	0	0	0	0	0	0	0	0
Total use of renewable primary energy resources (PERT)	MJ	8.17E+02	2.90E+01	3.88E+00	8.50E+02	0	6.45E+01	2.29E+00	6.40E-02	6.48E+02
Use of non-renewable primary energy (PENRE)	MJ	3.37E+04	5.45E+02	2.40E+02	3.45E+04	1.02E+02	1.14E+03	1.85E+02	7.38E+00	-1.64E+04
Non-renewable primary energy resources used as raw materials (PENRM)	MJ	0	0	0	0	0	0	0	0	0
Total use of non-renewable primary energy resources (PENRT)	MJ	3.37E+04	5.45E+02	2.40E+02	3.45E+04	1.02E+02	1.14E+03	1.86E+02	7.39E+00	-1.64E+04
Input of secondary material (SM)	Kg	0	0	0	0	0	0	0	0	0
Use of renewable secondary fuels (RSF)	MJ	0	0	0	0	0	0	0	0	0
Use of non-renewable secondary fuels (NRSF)	MJ	0	0	0	0	0	0	0	0	0
Use of net fresh water (FW)	m ³ eq.	1.18E+01	3.28E-02	2.13E+00	1.39E+01	0	7.30E-02	1.54E-01	7.88E-03	-1.67E+02

¹ This indicator accounts for all greenhouse gases except biogenic carbon dioxide uptake and emissions and biogenic carbon stored in the product. As such, the indicator is identical to GWP-total except that the CF for biogenic CO₂ is set to zero.

Waste production and output flows

PARAMETER	UNIT	A1	A2	A3	Total A1 – A3	C1	C2	C3	C4	D
Hazardous Waste Disposed	kg	1.47E-07	2.45E-09	4.35E-09	1.54E-07	0	5.45E-09	0	0	-1.23E-04
Non-hazardous Waste Disposed	kg	1.38E+00	7.32E-02	1.19E+00	2.64E+00	0	1.63E-01	0	0	1.99E+02
Radioactive Waste Disposed	kg	1.87E-02	6.29E-04	4.02E-03	2.33E-02	0	1.40E-03	0	0	1.80E-03
Components for Re-use	kg	0	0	0	0	0	0	0	0	0
Material for Recycling (MFR)	kg	0	0	0	0	0	0	0	0	0
Materials for Energy Recovery (MER)	kg	0	0	0	0	0	0	0	0	0
Exported Electricity Energy (EEE)	MJ	0	0	0	0	0	0	0	0	0
Exported Thermal Energy (EET)	MJ	0	0	0	0	0	0	0	0	0

Information on biogenic carbon content

Results per declared unit		
BIOGENIC CARBON CONTENT	Unit	QUANTITY
Biogenic carbon content in product	kg C	0
Biogenic carbon content in packaging	kg C	8.41E+00

Note: 1 kg biogenic carbon is equivalent to 44/12 kg CO₂.

Differences versus previous versions:

2023-08-22 Version 1

2023-11-08 Version 1.1

Editorial change: Modules A1, A2, and A3 values were changed in the Environmental information. But the sum of these things has not changed. It changed because there was an error in the process of classifying modules. And we added the sum of A1-A3 to the new column.

References

- The International EPD® System, The International EPD® System is a programme for type III environmental declarations, maintaining a system to verify and register EPD@s as well as keeping a library of EPD@s and PCRs in accordance with ISO 14025, www.environdec.com
- Product Category Rules (PCR): Construction products 2019:14, version 1.3.0
- General Programme Instructions of the International EPD® System. Version 4.0
- UL Product Category Rules (PCR) Guidance for Building Related Products and Services Part A: Life Cycle Assessment Calculation Rules and Report Requirements, UL 10010 Sixth Edition, Dated March 28, 2022
- ISO 14020:2000 Environmental labels and declarations - General principles
- ISO 14025:2006 Environmental labels and declarations - Type III environmental declarations - Principles and procedures
- ISO 14040:2006 Environmental management- Life cycle assessment - Principles and framework
- ISO 14044:2006 Environmental management - Life cycle assessment - Requirements and guidelines
- O. Bozdog and M. Secer, "Energy Consumption of RC Buildings during Their Life Cycle," Sustainable Construction, Materials and Practices: Challenge of the Industry for the New Millennium, Minho, 12-14 September 2007

