

Programme:

The International EPD[®] System:
www.environdec.com

Programme Operator:

EPD International AB

EPD Registration Number:

EPD-IES-0016597

Publication Date:

2024-10-28

Valid Until:

2029-10-28

In accordance with ISO 14025:2006 and
EN15804:2012+A2:2019/AC:2021 for:

GU10 LED LAMP

From Orlight Limited

EPD of multiple products, based on a representative product

Product model:

LX4 - SWITCHED, LX5 - MAINS DIMMABLE



An EPD should provide current information and may be updated if conditions change. The stated validity is therefore subject to the continued registration and publication at www.environdec.com



Programme Information:

Programme	The International EPD® System	Website	www.environdec.com
Address	EPD International AB Box 210 60 SE-100 31 Stockholm Sweden	E-mail	info@environdec.com

Product Category Rules (PCR):

CEN standard EN 15804 serves as the Core Product Category Rules (PCR)
Product Category Rules (PCR): PCR 2019:14 Construction products (EN 15804: A2) (1.3.4)
This EPD follows additional requirements for construction products considered as Electronic or Electric Equipment

PCR review was conducted by:

The Technical Committee of the International EPD® System. See www.environdec.com/TC for a list of members. Review chair: Claudia A. Peña, University of Concepción, Chile. The review panel may be contacted via the Secretariat www.environdec.com/contact

Life Cycle Assessment (LCA) accountability:

Bin Xu, CTI Certification Co., Ltd

Third party verification:

Independent third-party verification of the declaration and data, according to ISO 14025:2006, via:

EPD verification by individual verifier

Third-party verifier: Rui Wang, IVL Swedish Environmental Research Institute

Approved by: The International EPD® System

Procedure for follow-up of data during EPD validity involves third party verifier:

Yes No

The EPD owner has the sole ownership, liability, and responsibility for the EPD.

EPDs within the same product category but registered in different EPD programmes, or not compliant with EN 15804, may not be comparable. For two EPDs to be comparable, they must be based on the same PCR (including the same version number) or be based on fully aligned PCRs or versions of PCRs; cover products with identical functions, technical performances and use (e.g. identical declared/functional units); have equivalent system boundaries and descriptions of data; apply equivalent data quality requirements, methods of data collection, and allocation methods; apply identical cut-off rules and impact assessment methods (including the same version of characterisation factors); have equivalent content declarations; and be valid at the time of comparison. For further information about comparability, see EN 15804 and ISO 14025.



Owner of the EPD: ORLIGHT LIMITED **Contact:** Wilson Mendes **E-mail:** info@orlight.com

About Us

Orlight, your premier turn-key lighting supply partner. Established in 1997, Orlight has become a dominant force in the architectural lighting market, consistently adding value to our clients' propositions with unparalleled lighting products and services. Our unique approach to the ever-evolving industry has made us a trusted name among developers and construction firms.

Our Mission

We pride ourselves on being 100% in command of our supply chain, from quality control and product innovation to research, development and procurement. With no third-party involvement, we deliver superior products at competitive prices. Our substantial stock holdings in the UK and Europe ensure swift dispatch, minimising waiting times and providing a distinct advantage to our clients.

Market Sector and Credibility

Orlight caters to large-scale residential and commercial developments, in response to market demand, we expanded from a predominantly residential lighting business into the commercial lighting sector for data centres, office spaces and other commercial environments, which has proven a success for us. Our growing commercial product range combines high-specification LED technology with aesthetic appeal, ensuring first-class offerings that maintain critical performance values. Our reputation, built over more than 25 years, is reinforced by long-standing relationships with major developers and construction firms. We also serve a diverse portfolio of clients, with projects extending globally to the Middle East, Europe and China.

Sustainability Commitment

At Orlight, sustainability is a core value that informs all aspects of our business. We take our environmental responsibilities seriously, integrating eco-friendly practices throughout our supply chain and manufacturing processes. We are committed to reducing our carbon footprint and improving operational efficiency. We continuously seek ways to enhance our sustainability efforts, ensuring that our products are not only high-quality but also environmentally responsible.

Value Proposition and Deliverability

To streamline processes, we offer direct credit accounts to M&E Contractors, Electrical Installers and Construction Companies, now extending these facilities to North America, Europe and the Middle East. By eliminating third parties, we help clients control costs effectively. With stocks exceeding £10M and a fleet of vehicles, our FORS Gold Accredited operation guarantees high performance, safety and efficiency, reinforcing our commitment to a reliable Source to Site® service.

The Complete Project from Concept to Delivery

Orlight's Source to Site business model is rooted in value, quality and efficiency. Our comprehensive in-house departments provide a full spectrum of services, from initial design to bespoke product manufacturing and technical support. Our adaptability allows us to tackle various projects, including luxury Apartments, Commercial & Hospitality developments, Gyms, Spas, Data Centres and other areas located both internally and externally. This flexibility and control over our manufacturing process make Orlight a sought-after partner for high-end projects across London and beyond.

At Orlight, our commitment to innovation, quality, sustainability and client satisfaction drives us to deliver exceptional lighting solutions for every project. Join us in illuminating the future with excellence.

Product-related or management system-related certifications

- ISO 9001:2015 – Quality Management Service
- ISO 14001:2015 – Environmental Management System

Name and location of production site:

Anhui, China

Product Name:

This EPD[®] represents the LX family from Orlight, including the following models:

LX4 - SWITCHED



LX4

LX5 – MAINS DIMMABLE



LX5

Product Identification:

PRODUCT	WATTAGE	COLOUR TEMPERATURE	CONTROL
LX4	7W	2700K / 3000K / 4000K	SWITCHED
LX5	7W	2700K / 3000K / 4000K	MAINS DIMMABLE

The test standard of products refers to: IES LM-79-08, ANSI C78.377-2017

Manufacturing Process:



The GU10 LED LAMP products of LX family from Orlight are manufactured in the same site and have the same major steps in the core manufacturing processes, including raw material inspection, soldering, assembly, testing, etc. The products in this family (LX4-SWITCHED and LX5-MAINS DIMMABLE) have the same structure, function, size and wattage. The only difference is the control method, LX4 is switched and LX5 is mains dimmable.

This EPD of multiple products is based on the representative product, which is **LX5-MAINS DIMMABLE**, based on the sales revenue.

Product Description:

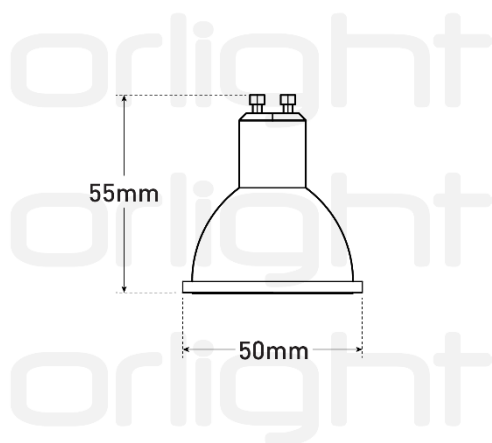

LX5-MAINS DIMMABLE

The LX5 mains dimmable lamp is engineered with precision to integrate a powerful 7W LED chipset within a compact form factor, making it an ideal solution for modern lighting applications. This advanced design leverages cutting-edge thermal management technology, which not only enhances the lamp's power efficiency but also ensures optimal performance even under prolonged use.

With a Colour Rendering Index (CRI) value exceeding 82, the LX5 guarantees superior light quality, faithfully reproducing colours for a more natural and vibrant illumination experience.

Incorporating a single high-power chipset further elevates the lamp's capabilities, delivering a consistent and uniform beam of light across its entire output, ensuring that every space is lit with precision and clarity.

In summary, the LX5 mains dimmable lamp embodies the perfect balance of innovation and functionality, offering a reliable, high-quality lighting solution in a sleek, space-saving design.

UN CPC Code:

4653 Lighting Equipment

Geographical Scope:

Modules A1-A3: CN

Modules A4-A5: GLO

Modules B and C: UK

Declared Unit:

One piece of GU10 LED LAMP product, the weight of the representative product per declared unit is 0.0252 kg.

Reference service life:

50,000 hours. In normal operational regime of 8 hours per day for 250 working days per year, the product lasts up to 25 years

Time representativeness:

From 1st June 2023 to 31st May 2024

Database(s) and LCA software used:

Database Ecoinvent 3.10 and Simapro 9.6

Cut-off criteria:

In the event of insufficient input data or data gaps for a unit process, the cut-off criteria should be set at 1% for both renewable and non-renewable primary energy usage, as well as 1% for the total mass input of that unit process. The cumulative neglected input flows A1-A3, A4-A5, B1-B7, C1-C4 and module D, shall not exceed 5% of energy usage and mass. In addition, the consumption and emissions of roads and plants' infrastructure, capital goods, equipment of each process, personnel and living facilities in the plants were excluded.

Allocation rules:

In this assessment, the allocation of energy consumption, resource use, emissions and wastes from the manufacturing process are based on economic values of the products when they leave the unit process, which is the revenue generated by GU10 LED LAMP and the other products, which are from the same manufacturing site of Orlight Limited. The revenue is the product annual average price multiplied by the output volume of products.

Description of system boundaries:

Cradle to gate with options, modules C1–C4, module D and with optional modules (A1–A3 + C + D + A4–A5 and B1-B7)

System diagram:

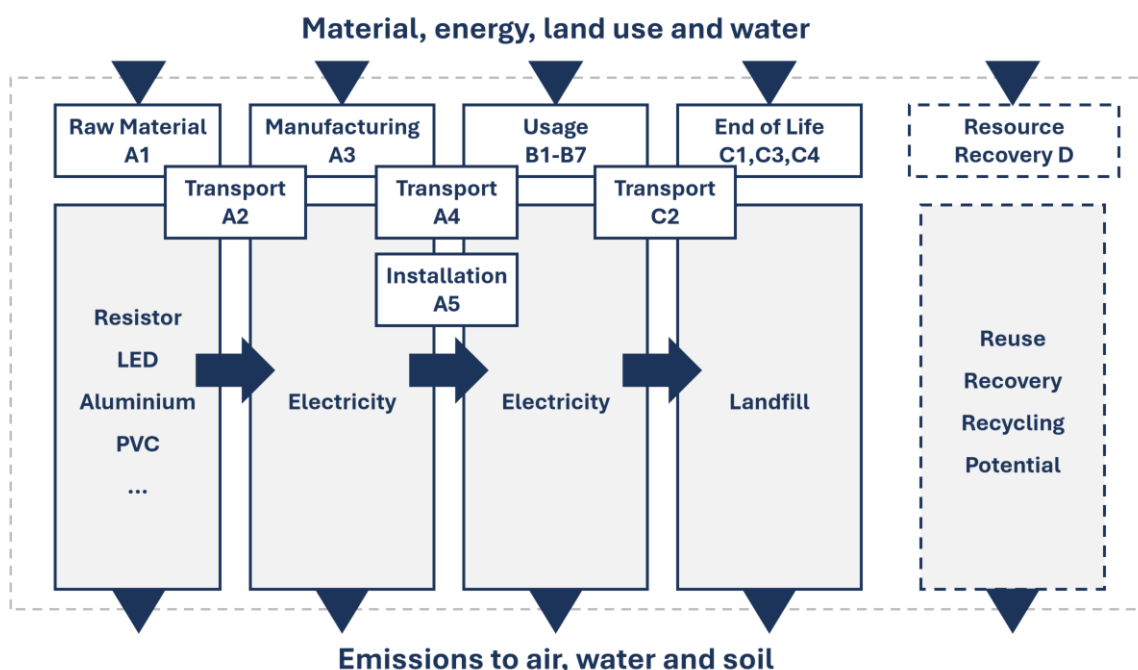

Assumptions:

At construction process stage A5, the transportation of the product to the customer or building site is considered, with the transport distance assumed to be 100 km. The product is installed manually.

In Module B6 operational energy use, the wattage of representative product is 7W. In normal operational regime of 8 hours per day for 250 working days per year, the product lasts up to 25 years, 50,000 hours in total.

At end-of-life stage C2, an average distance of 100 km is assumed for transport to the recycling facility and landfill site.

Additional information:

In this EPD, the EN 15804 reference package is based on EF 3.1

In this EPD, the benefits of 100% of scrap metal and 65% of the rest part from Linear LED product are included in module D. The same approach has been applied to packaging materials because all the packaging materials are 100% recycled by Orlight.

The data for the generation of electricity applied in A3 is electricity mixes on the market, namely the China Southern Power Grid Mix in the Ecoinvent 3.10 (cut-off) database. Its GWP-GHG impact is 0.703 kgCO₂eq/kWh. The reference year of electricity dataset is 2014-2022.

The data for the generation of electricity applied in B6 is electricity mixes on the market, namely the United Kingdom Power Grid Mix in the Ecoinvent 3.10 (cut-off) database. Its GWP-GHG impact is 0.261 kgCO₂eq/kWh. The reference year of electricity dataset is 2020-2023.

Conversion Factor:

PRODUCT	WEIGHT (KG/DECLARED UNIT)	CONVERSION FACTOR
LX5-MAINS DIMMABLE	0.0252	0.0252

Modules declared, geographical scope, share of specific data (in GWP-GHG results) and data variation (in GWP-GHG results):

	Product stage			Construction process stage		Use stage							End of life stage				Resource recovery stage	
	Raw material supply	Transport	Manufacturing	Transport	Construction installation	Use	Maintenance	Repair	Replacement	Refurbishment	Operational energy use	Operational water use	De-construction demolition	Transport	Waste processing	Disposal	Reuse-Recovery-Recycling-potential	
Module	A1	A2	A3	A4	A5	B1	B2	B3	B4	B5	B6	B7	C1	C2	C3	C4	D	
Modules declared	X	X	X	X	X	X	X	X	X	X	X	X	X	X	X	X	X	X
Geography	CN	CN	CN	GLO	GLO	UK	UK	UK	UK	UK	UK	UK	UK	UK	UK	UK	UK	
Specific data used	3.79%			-	-	-	-	-	-	-	-	-	-	-	-	-	-	
Variation – products	-6.43% / 0%			-	-	-	-	-	-	-	-	-	-	-	-	-	-	
Variation – sites	0%			-	-	-	-	-	-	-	-	-	-	-	-	-	-	

The content information below is based on 1 piece of LX5-MAINS DIMMABLE product, which is the representative product within the LX family. The product weight is 0.0252 kg, excluding packaging materials. As the share of bio-based/recycled material is unknown, this part of the content declaration is declared as 0% as a conservative estimation.

Product components	Weight, kg	Post-consumer material, weight-%	Biogenic material, weight-% and kg C/kg
Printed Wiring Board	8.00E-04	0	0
Resistor	3.00E-04	0	0
Silicon	1.00E-04	0	0
Capacitor	1.40E-03	0	0
Inductor	2.00E-03	0	0
Aluminium	3.30E-03	0	0
LED	1.00E-04	0	0
Copper	2.00E-04	0	0
PVC	1.60E-02	0	0
Ceramic Capacitor	2.00E-04	0	0
Transformer	8.00E-04	0	0
TOTAL	2.52E-02	0	0
Packaging materials	Weight, kg	Weight-% (versus the product)	Weight biogenic carbon, kg C/kg
Corrugated board	1.19E-02	32.08%	0
TOTAL	1.19E-02	32.08%	0

Dangerous substances from the candidate list of SVHC for Authorisation	EC No.	CAS No.	Weight-% per functional or declared unit
None	-	-	-

The product does not include in its life cycle any dangerous substances included in the "Very High Impact Candidate List for Authorization (SVHC)" in a percentage greater than 0.1% of the weight of the product.

Results of the environmental performance indicators

Mandatory impact category indicators according to EN 15804:

Results per declared unit																
Indicator	Unit	A1-A3	A4	A5	B1	B2	B3	B4	B5	B6	B7	C1	C2	C3	C4	D
GWP-fossil	kg CO ₂ eq.	6.50E-01	2.94E-01	1.87E-04	0.00E+00	0.00E+00	0.00E+00	0.00E+00	0.00E+00	9.11E+01	0.00E+00	0.00E+00	3.93E-04	0.00E+00	3.85E-04	-4.14E-01
GWP-biogenic	kg CO ₂ eq.	-6.11E-03	3.25E-05	1.10E-08	0.00E+00	0.00E+00	0.00E+00	0.00E+00	0.00E+00	1.72E-01	0.00E+00	0.00E+00	2.32E-08	0.00E+00	5.26E-03	1.10E-02
GWP-luluc	kg CO ₂ eq.	8.76E-04	2.14E-05	7.64E-08	0.00E+00	0.00E+00	0.00E+00	0.00E+00	0.00E+00	1.11E-01	0.00E+00	0.00E+00	1.60E-07	0.00E+00	1.08E-07	-6.11E-04
GWP-total	kg CO ₂ eq.	6.45E-01	2.94E-01	1.87E-04	0.00E+00	0.00E+00	0.00E+00	0.00E+00	0.00E+00	9.14E+01	0.00E+00	0.00E+00	3.94E-04	0.00E+00	5.64E-03	-4.04E-01
ODP	kg CFC 11 eq.	3.63E-08	4.52E-09	2.73E-12	0.00E+00	0.00E+00	0.00E+00	0.00E+00	0.00E+00	4.61E-06	0.00E+00	0.00E+00	5.72E-12	0.00E+00	2.59E-12	-2.36E-08
AP	mol H ⁺ eq.	9.28E-03	1.36E-03	8.51E-07	0.00E+00	0.00E+00	0.00E+00	0.00E+00	0.00E+00	3.38E-01	0.00E+00	0.00E+00	1.79E-06	0.00E+00	1.30E-06	-6.05E-03
EP-freshwater	kg P eq.	6.49E-04	4.32E-06	1.50E-08	0.00E+00	0.00E+00	0.00E+00	0.00E+00	0.00E+00	1.64E-02	0.00E+00	0.00E+00	3.16E-08	0.00E+00	5.77E-07	-4.24E-04
EP-marine	kg N eq.	9.83E-04	5.32E-04	3.19E-07	0.00E+00	0.00E+00	0.00E+00	0.00E+00	0.00E+00	7.32E-02	0.00E+00	0.00E+00	6.71E-07	0.00E+00	1.09E-05	-6.33E-04
EP-terrestrial	mol N eq.	1.09E-02	5.82E-03	3.48E-06	0.00E+00	0.00E+00	0.00E+00	0.00E+00	0.00E+00	8.47E-01	0.00E+00	0.00E+00	7.32E-06	0.00E+00	4.03E-06	-7.02E-03
POCP	kg NMVOC eq.	3.97E-03	1.84E-03	1.20E-06	0.00E+00	0.00E+00	0.00E+00	0.00E+00	0.00E+00	2.37E-01	0.00E+00	0.00E+00	2.52E-06	0.00E+00	2.55E-06	-2.56E-03
ADP-minerals&metals*	kg Sb eq.	1.71E-04	7.57E-08	5.86E-10	0.00E+00	0.00E+00	0.00E+00	0.00E+00	0.00E+00	1.53E-03	0.00E+00	0.00E+00	1.23E-09	0.00E+00	2.67E-10	-1.12E-04
ADP-fossil*	MJ	8.77E+00	3.90E+00	2.67E-03	0.00E+00	0.00E+00	0.00E+00	0.00E+00	0.00E+00	2.47E+03	0.00E+00	0.00E+00	5.60E-03	0.00E+00	2.44E-03	-5.61E+00
WDP*	m ³	2.42E-01	5.50E-03	1.27E-05	0.00E+00	0.00E+00	0.00E+00	0.00E+00	0.00E+00	8.12E+00	0.00E+00	0.00E+00	2.68E-05	0.00E+00	-1.23E-03	-1.62E-01
Acronyms	GWP-fossil = Global Warming Potential fossil fuels; GWP-biogenic = Global Warming Potential biogenic; GWP-luluc = Global Warming Potential land use and land use change; ODP = Depletion potential of the stratospheric ozone layer; AP = Acidification potential, Accumulated Exceedance; EP-freshwater = Eutrophication potential, fraction of nutrients reaching freshwater end compartment; EP-marine = Eutrophication potential, fraction of nutrients reaching marine end compartment; EP-terrestrial = Eutrophication potential, Accumulated Exceedance; POCP = Formation potential of tropospheric ozone; ADP-minerals&metals = Abiotic depletion potential for non-fossil resources; ADP-fossil = Abiotic depletion for fossil resources potential; WDP = Water (user) deprivation potential, deprivation-weighted water consumption															
Disclaimer: The use of the results of Modules A1-A3 (A1-A5 for services) without considering the results of Module C is discouraged. The estimated impact results are only relative statements, which do not indicate the endpoints of the impact categories, exceeding threshold values, safety margins and/or risks.																

* Disclaimer: The results of this environmental impact indicator shall be used with care as the uncertainties of these results are high or as there is limited experience with the indicator.

Results of the environmental performance indicators

Additional mandatory and voluntary impact category indicators:

Results per declared unit																
Indicator	Unit	A1-A3	A4	A5	B1	B2	B3	B4	B5	B6	B7	C1	C2	C3	C4	D
GWP-GHG ¹	kg CO ₂ eq.	6.51E-01	2.94E-01	1.87E-04	0.00E+00	0.00E+00	0.00E+00	0.00E+00	0.00E+00	9.12E+01	0.00E+00	0.00E+00	3.94E-04	0.00E+00	3.85E-04	-4.15E-01

This indicator accounts for all greenhouse gases except biogenic carbon dioxide uptake and emissions and biogenic carbon stored in the product. As such, the indicator is identical to GWP-total except that the CF for biogenic CO₂ is set to zero.

Results of the environmental performance indicators

Resource use indicators:

Results per declared unit																
Indicator	Unit	A1-A3	A4	A5	B1	B2	B3	B4	B5	B6	B7	C1	C2	C3	C4	D
PERE	MJ	8.94E-01	1.33E-02	3.49E-05	0.00E+00	0.00E+00	0.00E+00	0.00E+00	0.00E+00	7.85E+02	0.00E+00	0.00E+00	7.33E-05	0.00E+00	7.39E-05	-7.33E-01
PERM	MJ	1.91E-01	0.00E+00	0.00E+00	0.00E+00	0.00E+00	0.00E+00	0.00E+00	0.00E+00	0.00E+00	0.00E+00	0.00E+00	0.00E+00	0.00E+00	0.00E+00	0.00E+00
PERT	MJ	1.09E+00	1.33E-02	3.49E-05	0.00E+00	0.00E+00	0.00E+00	0.00E+00	0.00E+00	7.85E+02	0.00E+00	0.00E+00	7.33E-05	0.00E+00	7.39E-05	-7.33E-01
PENRE	MJ	8.48E+00	3.90E+00	2.67E-03	0.00E+00	0.00E+00	0.00E+00	0.00E+00	0.00E+00	2.47E+03	0.00E+00	0.00E+00	5.60E-03	0.00E+00	2.44E-03	-5.61E+00
PENRM	MJ	2.90E-01	0.00E+00	0.00E+00	0.00E+00	0.00E+00	0.00E+00	0.00E+00	0.00E+00	0.00E+00	0.00E+00	0.00E+00	0.00E+00	0.00E+00	0.00E+00	0.00E+00
PENRT	MJ	8.77E+00	3.90E+00	2.67E-03	0.00E+00	0.00E+00	0.00E+00	0.00E+00	0.00E+00	2.47E+03	0.00E+00	0.00E+00	5.60E-03	0.00E+00	2.44E-03	-5.61E+00
SM	kg	0.00E+00	0.00E+00	0.00E+00	0.00E+00	0.00E+00	0.00E+00	0.00E+00	0.00E+00	0.00E+00	0.00E+00	0.00E+00	0.00E+00	0.00E+00	0.00E+00	0.00E+00
RSF	MJ	0.00E+00	0.00E+00	0.00E+00	0.00E+00	0.00E+00	0.00E+00	0.00E+00	0.00E+00	0.00E+00	0.00E+00	0.00E+00	0.00E+00	0.00E+00	0.00E+00	0.00E+00
NRSF	MJ	0.00E+00	0.00E+00	0.00E+00	0.00E+00	0.00E+00	0.00E+00	0.00E+00	0.00E+00	0.00E+00	0.00E+00	0.00E+00	0.00E+00	0.00E+00	0.00E+00	0.00E+00
FW	M ³	8.36E-03	1.85E-04	3.77E-07	0.00E+00	0.00E+00	0.00E+00	0.00E+00	0.00E+00	5.84E-01	0.00E+00	0.00E+00	7.92E-07	0.00E+00	-2.86E-05	-5.62E-03
Acronyms	PERE = Use of renewable primary energy excluding renewable primary energy resources used as raw materials; PERM = Use of renewable primary energy resources used as raw materials; PERT = Total use of renewable primary energy resources; PENRE = Use of non-renewable primary energy excluding non-renewable primary energy resources used as raw materials; PENRM = Use of non-renewable primary energy resources used as raw materials; PENRT = Total use of non-renewable primary energy re-sources; SM = Use of secondary material; RSF = Use of renewable secondary fuels; NRSF = Use of non-renewable secondary fuels; FW = Use of net fresh water															

Results of the environmental performance indicators

Waste indicators:

Results per declared unit																
Indicator	Unit	A1-A3	A4	A5	B1	B2	B3	B4	B5	B6	B7	C1	C2	C3	C4	D
Hazardous waste disposed	kg	5.12E-04	4.04E-05	7.05E-08	0.00E+00	0.00E+00	0.00E+00	0.00E+00	0.00E+00	1.50E-01	0.00E+00	0.00E+00	1.48E-07	0.00E+00	1.15E-06	-3.10E-04
Non-hazardous waste disposed	kg	3.30E-02	7.13E-03	1.63E-04	0.00E+00	0.00E+00	0.00E+00	0.00E+00	0.00E+00	6.50E+00	0.00E+00	0.00E+00	3.42E-04	0.00E+00	7.63E-03	-2.08E-02
Radioactive waste disposed	kg	1.66E-05	2.63E-07	5.65E-10	0.00E+00	0.00E+00	0.00E+00	0.00E+00	0.00E+00	1.89E-02	0.00E+00	0.00E+00	1.19E-09	0.00E+00	1.48E-09	-1.05E-05

Output flow indicators:

Results per declared unit																
Indicator	Unit	A1-A3	A4	A5	B1	B2	B3	B4	B5	B6	B7	C1	C2	C3	C4	D
Components for re-use	kg	0.00E+00	0.00E+00	0.00E+00	0.00E+00	0.00E+00	0.00E+00	0.00E+00	0.00E+00	0.00E+00	0.00E+00	0.00E+00	0.00E+00	0.00E+00	0.00E+00	0.00E+00
Material for recycling	kg	0.00E+00	0.00E+00	0.00E+00	0.00E+00	0.00E+00	0.00E+00	0.00E+00	0.00E+00	0.00E+00	0.00E+00	0.00E+00	0.00E+00	0.00E+00	0.00E+00	2.95E-02
Materials for energy recovery	kg	0.00E+00	0.00E+00	0.00E+00	0.00E+00	0.00E+00	0.00E+00	0.00E+00	0.00E+00	0.00E+00	0.00E+00	0.00E+00	0.00E+00	0.00E+00	0.00E+00	0.00E+00
Exported energy, electricity	MJ	0.00E+00	0.00E+00	0.00E+00	0.00E+00	0.00E+00	0.00E+00	0.00E+00	0.00E+00	0.00E+00	0.00E+00	0.00E+00	0.00E+00	0.00E+00	0.00E+00	0.00E+00
Exported energy, thermal	MJ	0.00E+00	0.00E+00	0.00E+00	0.00E+00	0.00E+00	0.00E+00	0.00E+00	0.00E+00	0.00E+00	0.00E+00	0.00E+00	0.00E+00	0.00E+00	0.00E+00	0.00E+00

Results of the environmental performance indicators

The variation of mandatory impact category indicators according to EN 15804:

Variation from module A to C			
Indicator	Unit	Variation from module A to C	
GWP-fossil	kg CO ₂ eq.	-0.05%	0.00%
GWP-biogenic	kg CO ₂ eq.	0.12%	0.00%
GWP-luluc	kg CO ₂ eq.	-0.03%	0.00%
GWP-total	kg CO ₂ eq.	-0.05%	0.00%
ODP	kg CFC 11 eq.	-0.12%	0.00%
AP	mol H ⁺ eq.	-0.06%	0.00%
EP-freshwater	kg P eq.	-0.07%	0.00%
EP-marine	kg N eq.	-0.10%	0.00%
EP-terrestrial	mol N eq.	-0.09%	0.00%
POCP	kg NMVOC eq.	-0.11%	0.00%
ADP-minerals&metals*	kg Sb eq.	-0.29%	0.00%
ADP-fossil*	MJ	-0.02%	0.00%
WDP*	m ³	-0.16%	0.00%
Acronyms	GWP-fossil = Global Warming Potential fossil fuels; GWP-biogenic = Global Warming Potential biogenic; GWP-luluc = Global Warming Potential land use and land use change; ODP = Depletion potential of the stratospheric ozone layer; AP = Acidification potential, Accumulated Exceedance; EP-freshwater = Eutrophication potential, fraction of nutrients reaching freshwater end compartment; EP-marine = Eutrophication potential, fraction of nutrients reaching marine end compartment; EP-terrestrial = Eutrophication potential, Accumulated Exceedance; POCP = Formation potential of tropospheric ozone; ADP-minerals&metals = Abiotic depletion potential for non-fossil resources; ADP-fossil = Abiotic depletion for fossil resources potential; WDP = Water (user) deprivation potential, deprivation-weighted water consumption		

ISO 14025:2010 Environmental labels and declarations - Type III environmental declarations - Principles and procedures.

ISO 14040:2006 Environmental management - Life cycle assessment - Principles and frameworks.

ISO 14044:2006 Environmental management - Life cycle assessment - Requirements and guidelines.

EN 15804:2012 +A2:2019/AC:2021 Sustainability in construction works - Environmental product declarations - Core rules for the product category of construction products.

EPD System PCR 2019:14 Construction products, version 1.3.4

General Programme Instructions of the International EPD® system. Version 5.0

orlight®
FROM SOURCE TO SITE

www.orlight.com | info@orlight.com